



An Oshkosh Corporation Company

---

# ***Operation and Safety Manual***

*Keep this manual with the machine at all times.*

**LIFTLUX**

**Models**

**210-25 & 245-25**

**Prior to S/N 20465**

**Excluding S/N's: 16563, 18190, 19542,  
19543, 19933, 20020, 20242, & 20317**



**P/N - 3121303**

*September 26, 2008*

---



## **FOREWORD**

This manual is a very important tool! Keep it with the machine at all times.

The purpose of this manual is to provide owners, users, operators, lessors, and lessees with the precautions and operating procedures essential for the safe and proper machine operation for its intended purpose.

Due to continuous product improvements, JLG Industries, Inc. reserves the right to make specification changes without prior notification. Contact JLG Industries, Inc. for updated information.

## SAFETY ALERT SYMBOLS AND SAFETY SIGNAL WORDS



This is the Safety Alert Symbol. It is used to alert you to the potential personal injury hazards. Obey all safety messages that follow this symbol to avoid possible injury or death

### **DANGER**

INDICATES AN IMMINENTLY HAZARDOUS SITUATION. IF NOT AVOIDED, WILL RESULT IN SERIOUS INJURY OR DEATH. THIS DECAL WILL HAVE A RED BACKGROUND.

### **WARNING**

INDICATES A POTENTIALITY HAZARDOUS SITUATION. IF NOT AVOIDED, COULD RESULT IN SERIOUS INJURY OR DEATH. THIS DECAL WILL HAVE AN ORANGE BACKGROUND.

### **CAUTION**

INDICATES A POTENTIALITY HAZARDOUS SITUATION. IF NOT AVOIDED, MAY RESULT IN MINOR OR MODERATE INJURY. IT MAY ALSO ALERT AGAINST UNSAFE PRACTICES. THIS DECAL WILL HAVE A YELLOW BACKGROUND.

**⚠ WARNING**

THIS PRODUCT MUST COMPLY WITH ALL SAFETY RELATED BULLETINS. CONTACT JLG INDUSTRIES, INC. OR THE LOCAL AUTHORIZED JLG REPRESENTATIVE FOR INFORMATION REGARDING SAFETY-RELATED BULLETINS WHICH MAY HAVE BEEN ISSUED FOR THIS PRODUCT.

**NOTICE**

JLG INDUSTRIES, INC. SENDS SAFETY RELATED BULLETINS TO THE OWNER OF RECORD OF THIS MACHINE. CONTACT JLG INDUSTRIES, INC. TO ENSURE THAT THE CURRENT OWNER RECORDS ARE UPDATED AND ACCURATE.

**NOTICE**

JLG INDUSTRIES, INC. MUST BE NOTIFIED IMMEDIATELY IN ALL INSTANCES WHERE JLG PRODUCTS HAVE BEEN INVOLVED IN AN ACCIDENT INVOLVING BODILY INJURY OR DEATH OF PERSONNEL OR WHEN SUBSTANTIAL DAMAGE HAS OCCURRED TO PERSONAL PROPERTY OR THE JLG PRODUCT.

**For:**

- Accident Reporting
- Product Safety Publications
- Current Owner Updates
- Questions Regarding Product Safety
- Standards and Regulations Compliance Information
- Questions Regarding Special Product Applications
- Questions Regarding Product Modifications

**Contact:**

Product Safety and Reliability Department  
JLG Industries, Inc.  
13224 Fountainhead Plaza  
Hagerstown, MD 21742

or Your Local JLG Office  
(See addresses on rear cover)

**In USA:**

Toll Free: 877-JLG-SAFE (877-554-7233)

**Outside USA:**

Phone: 240-420-2661  
E-mail: ProductSafety@JLG.com

## **REVISION LOG**

Original Issue	- May 5, 2005
Revised	- May 23, 2005
Revised	- July 31, 2006
Revised	- July 3, 2008
Revised	- September 26, 2008

<b>SECTION - PARAGRAPH, SUBJECT</b>	<b>PAGE</b>
<b>SECTION - 1 - SAFETY PRECAUTIONS</b>	
1.1 GENERAL . . . . .	1-1
1.2 PRE-OPERATION . . . . .	1-1
Operator Training and Knowledge . . . . .	1-1
Workplace Inspection . . . . .	1-2
Machine Inspection . . . . .	1-3
1.3 OPERATION . . . . .	1-3
General . . . . .	1-3
Trip and Fall Hazards . . . . .	1-4
Electrocution Hazards . . . . .	1-5
Tipping Hazards . . . . .	1-7
Crushing and Collision Hazards . . . . .	1-8
1.4 TOWING, LIFTING, AND HAULING . . . . .	1-9
1.5 MAINTENANCE . . . . .	1-9
General . . . . .	1-9
Maintenance Hazards . . . . .	1-10
Battery Hazards . . . . .	1-10
<b>SECTION - 2 - USER RESPONSIBILITIES, MACHINE PREPARATION AND INSPECTION</b>	
2.1 PERSONNEL TRAINING . . . . .	2-1
Operator Training . . . . .	2-1
Training Supervision . . . . .	2-1
Operator Responsibility . . . . .	2-1

<b>SECTION - PARAGRAPH, SUBJECT</b>	<b>PAGE</b>
2.2 PREPARATION, INSPECTION, AND MAINTENANCE . . . . .	2-2
2.3 PRE-START INSPECTION . . . . .	2-4
Function Check . . . . .	2-5
General . . . . .	2-8
<b>SECTION - 3 - USER RESPONSIBILITIES AND MACHINE CONTROL</b>	
3.1 GENERAL . . . . .	3-1
3.2 PERSONNEL TRAINING . . . . .	3-1
Operator Training . . . . .	3-1
Training Supervision . . . . .	3-2
Operator Responsibility . . . . .	3-2
3.3 OPERATING CHARACTERISTICS AND LIMITATIONS . . . . .	3-2
General . . . . .	3-2
Placards . . . . .	3-2
Capacities . . . . .	3-3
3.4 CONTROLS AND INDICATORS . . . . .	3-3
Ground Control Stations . . . . .	3-3
Engine Control . . . . .	3-4
Power Outrigger . . . . .	3-7
3.5 PLATFORM CONTROL STATION . . . . .	3-8
Platform Control Descriptions . . . . .	3-9

## TABLE OF CONTENTS

SECTION - PARAGRAPH, SUBJECT	PAGE	SECTION - PARAGRAPH, SUBJECT	PAGE
<b>SECTION - 4 - MACHINE OPERATION</b>		<b>SECTION - 5 - EMERGENCY PROCEDURES</b>	
4.1 DESCRIPTION . . . . .	4-1	5.1 GENERAL . . . . .	5-1
General Description of the Functions and Components. . . . .	4-1	Emergency Stop Switch . . . . .	5-1
Tilt Switch . . . . .	4-1	Platform Caught Overhead. . . . .	5-1
High Drive Speed Cutout . . . . .	4-3	Righting of Tipped Machine . . . . .	5-1
Maximum Height Cutout . . . . .	4-3	Post-Incident Inspection . . . . .	5-1
Maximum Drive Height Cutout. . . . .	4-3	5.2 EMERGENCY OPERATION . . . . .	5-2
Oscillating Axle Limit Switch . . . . .	4-3	Operator Unable to Control Machine . . . . .	5-2
Platform Extend/Drive/Lift Select . . . . .	4-3	5.3 MANUAL DESCENT . . . . .	5-2
Load Sensing System (LSS) . . . . .	4-4	Manual Platform Deck Retraction. . . . .	5-4
4.2 OPERATION. . . . .	4-5	5.4 EMERGENCY TOWING . . . . .	5-5
4.3 LIFTING AND LOWERING . . . . .	4-6	Prior to Towing . . . . .	5-5
4.4 AUTOMATIC SELF LEVELING. . . . .	4-6	Incident Notification . . . . .	5-6
4.5 DRIVING THE MACHINE FROM THE PLATFORM . . . . .	4-7	<b>SECTION - 6 - GENERAL SPECIFICATIONS AND OPERATOR MAINTENANCE</b>	
4.6 STEERING . . . . .	4-7	6.1 INTRODUCTION . . . . .	6-1
4.7 HYDRAULIC PLATFORM EXTENSION . . . . .	4-7	6.2 OPERATING SPECIFICATIONS . . . . .	6-2
4.8 EMERGENCY LOWERING - MANUAL DESCENT . . . . .	4-7	Dimensional Data . . . . .	6-3
4.9 PARKING AND STOWING . . . . .	4-8	Capacities . . . . .	6-3
4.10 LIMIT SWITCHES & SAFETY DEVICES . . . . .	4-8	Engine . . . . .	6-4
4.11 TIE DOWN/LIFT LUGS. . . . .	4-9	Component Weights . . . . .	6-4
Tie Down . . . . .	4-9	Lubrication . . . . .	6-7
Lifting . . . . .	4-9	6.3 OPERATOR MAINTENANCE . . . . .	6-8
4.12 TRANSPORT AND STORAGE OF THE MACHINE . . . . .	4-10	6.4 TIRES AND WHEELS . . . . .	6-13



<b>SECTION - PARAGRAPH, SUBJECT</b>	<b>PAGE</b>
Tire Damage . . . . .	6-13
Tire Replacement . . . . .	6-14
Wheel Replacement . . . . .	6-14
Wheel Installation . . . . .	6-15
6.5 LSS TESTING AND EVALUATION . . . . .	6-16

**SECTION - 7 - INSPECTION AND REPAIR LOG**

<b>SECTION - PARAGRAPH, SUBJECT</b>	<b>PAGE</b>
<b>LIST OF FIGURES</b>	
2-1. Walk - Around Inspection Diagram . . . . .	2-7
2-2. Walk - Around Inspection Points (Sheet 1) . . . . .	2-8
2-3. Walk - Around Inspection Points (Sheet 2) . . . . .	2-9
3-1. Ground Control Stations . . . . .	3-3
3-2. Engine Control . . . . .	3-4
3-3. Platform Ground Control . . . . .	3-5
3-4. Power Outriggers . . . . .	3-7
3-5. Platform Control Station . . . . .	3-8
3-6. Decal Location - Sheet 1 of 3 . . . . .	3-11
3-7. Decal Location - Sheet 2 of 3 . . . . .	3-12
3-8. Decal Location - Sheet 3 of 3 . . . . .	3-13
4-1. Grade and Sideslope . . . . .	4-2
4-2. Lifting and Tie Down Location . . . . .	4-9
5-1. Drive Disconnect Hub . . . . .	5-5
6-1. Engine Operating Temperature Specifications (Deutz) - Sheet 1 of 2 . . . . .	6-5
6-2. Engine Operating Temperature Specifications (Deutz) - Sheet 2 of 2 . . . . .	6-6
6-3. Operator Maintenance & Lubrication Diagram . . .	6-8

# TABLE OF CONTENTS

---

SECTION - PARAGRAPH, SUBJECT	PAGE	SECTION - PARAGRAPH, SUBJECT	PAGE
<b>LIST OF TABLES</b>			
1-1	Minimum Safe Approach Distances (M.S.A.D.) . . .		1-6
2-1	Inspection and Maintenance Table . . . . .		2-3
3-1	Decal Legend. . . . .		3-14
6-1	Operating Specifications . . . . .		6-2
6-2	Dimensional Data. . . . .		6-3
6-3	Capacities . . . . .		6-3
6-4	Tire Specifications . . . . .		6-3
6-5	Engine Specifications . . . . .		6-4
6-6	Engine Battery Specifications . . . . .		6-4
6-7	Component Weights . . . . .		6-4
6-8	Hydraulic Oil . . . . .		6-7
6-9	Lubrication Specifications . . . . .		6-7
7-1	Inspection and Repair Log . . . . .		7-1

## SECTION 1. SAFETY PRECAUTIONS

### 1.1 GENERAL

This section outlines the necessary precautions for proper and safe machine usage and maintenance. In order to promote proper machine usage, it is mandatory that a daily routine is established based on the content of this manual. A maintenance program, using the information provided in this manual and the Service and Maintenance Manual, must also be established by a qualified person and must be followed to ensure that the machine is safe to operate.

The owner/user/operator/lessor/lessee of the machine should not accept operating responsibility until this manual has been read, training is accomplished, and operation of the machine has been completed under the supervision of an experienced and qualified operator.

These sections contain the responsibilities of the owner, user, operator, lessor, and lessee concerning safety, training, inspection, maintenance, application, and operation. If there are any questions with regard to safety, training, inspection, maintenance, application, and operation, please contact JLG Industries, Inc. ("JLG").

### **⚠ WARNING**

**FAILURE TO COMPLY WITH THE SAFETY PRECAUTIONS LISTED IN THIS MANUAL COULD RESULT IN MACHINE DAMAGE, PROPERTY DAMAGE, PERSONAL INJURY OR DEATH.**

### 1.2 PRE-OPERATION

#### Operator Training and Knowledge

- The Operators and Safety Manual must be read in its entirety before operating the machine. For clarification, questions, or additional information regarding any portions of this manual, contact JLG Industries, Inc.

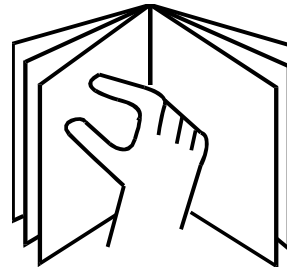

## **SECTION 1 - SAFETY PRECAUTIONS**

---

- An operator must not accept operating responsibilities until adequate training has been given by competent and authorized persons.
- Allow only those authorized and qualified personnel to operate the machine who have demonstrated that they understand the safe and proper operation and maintenance of the unit.
- Read, understand, and obey all DANGERS, WARNINGS, CAUTIONS, and operating instructions on the machine and in this manual.
- Ensure that the machine is to be used in a manner which is within the scope of its intended application as determined by JLG.
- All operating personnel must be familiar with the emergency controls and emergency operation of the machine as specified in this manual.
- Read, understand, and obey all applicable employer, local, and governmental regulations as they pertain to your utilization and application of the machine.
- Do not operate or raise the platform from a position on trucks, trailers, railway cars, floating vessels, scaffolds or other equipment unless the application is approved in writing by JLG.
- Before operation, check work area for overhead hazards such as electric lines, bridge cranes, and other potential overhead obstructions.
- Check floor surfaces for holes, bumps, drop-offs, obstructions, debris, concealed holes, and other potential hazards.
- Check the work area for hazardous locations. Do not operate the machine in hazardous environments unless approved for that purpose by JLG.
- Ensure that the ground conditions are adequate to support the maximum tire load indicated on the tire load decals located on the chassis adjacent to each wheel.
- Do not operate the machine when wind conditions exceed 12.5 m/s (28 mph).
- This machine can be operated in nominal ambient temperatures of -15°C to 45°C (5°F to 113°F). Consult JLG to optimize operation outside of this temperature range.

### **Workplace Inspection**

- Precautions to avoid all hazards in the work area must be taken by the user before operation of the machine.

### Machine Inspection

- Do not operate this machine until the inspections and functional checks have been performed as specified in Section 2 of this manual.
- Do not operate this machine until it has been serviced and maintained according to the maintenance and inspection requirements as specified in the machine's Service and Maintenance Manual.
- Ensure all safety devices are operating properly. Modification of these devices is a safety violation.

#### **WARNING**

**MODIFICATION OR ALTERATION OF AN AERIAL WORK PLATFORM SHALL BE MADE ONLY WITH PRIOR WRITTEN PERMISSION FROM THE MANUFACTURER.**

- Do not operate any machine on which the safety or instruction placards or decals are missing or illegible.
- Check the machine for modifications to original components. Ensure that any modifications have been approved by JLG.
- Avoid accumulation of debris on platform deck. Keep mud, oil, grease, and other slippery substances from footwear and platform deck.

### 1.3 OPERATION

#### General

- Do not use the machine for any purpose other than positioning personnel, their tools, and equipment.
- Before operation, the user must be familiar with the machine capabilities and operating characteristics of all functions.
- Never operate a malfunctioning machine. If a malfunction occurs, shut down the machine. Remove the unit from service and notify the proper authorities.
- Do not remove, modify, or disable any safety devices.
- Never slam a control switch or lever through neutral to an opposite direction. Always return switch to neutral and stop before moving the switch to the next function. Operate controls with slow and even pressure.
- Do not allow personnel to tamper with or operate the machine from the ground with personnel in the platform, except in an emergency.
- Do not carry materials directly on platform railing unless approved by JLG.
- When two or more persons are in the platform, the operator shall be responsible for all machine operations.

## SECTION 1 - SAFETY PRECAUTIONS

---

- Always ensure that power tools are properly stowed and never left hanging by their cord from the platform work area.
- Do not assist a stuck or disabled machine by pushing or pulling except by pulling at the chassis tie-down lugs.
- Stow scissor arm assembly and shut off all power before leaving machine.

### Trip and Fall Hazards

- JLG Industries, Inc. recommends that all persons in the platform wear a full body harness with a lanyard attached to an authorized lanyard anchorage point while operating this machine. For further information regarding fall protection requirements on JLG products, contact JLG Industries, Inc.

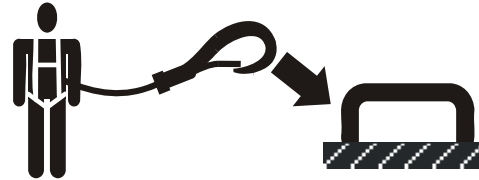

- Prior to operation, ensure all gates and rails are fastened and secured in their proper position. Identify the designated lanyard anchorage point(s) at the platform and securely attach the lanyard. Attach only one (1) lanyard per lanyard anchorage point.

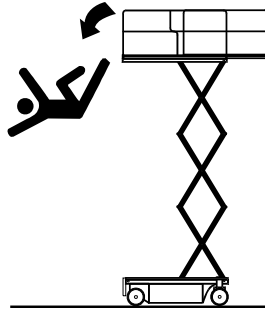

- Keep both feet firmly positioned on the platform floor at all times. Never position ladders, boxes, steps, planks, or similar items on unit to provide additional reach for any purpose.
- Never use the scissor arm assembly to gain access to or leave the platform.
- Use extreme caution when entering or leaving platform. Ensure that the scissor arm assembly is fully lowered. Face the machine when entering or leaving the platform. Always maintain “three point contact” with the machine, using two hands and one foot or two feet and one hand at all times during entry and exit.
- Keep oil, mud, and slippery substances cleaned from footwear and the platform floor.

### Electrocution Hazards

- This machine is not insulated and does not provide protection from contact with an electrically charged conductor.

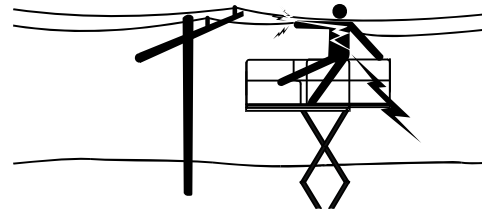

## SECTION 1 - SAFETY PRECAUTIONS

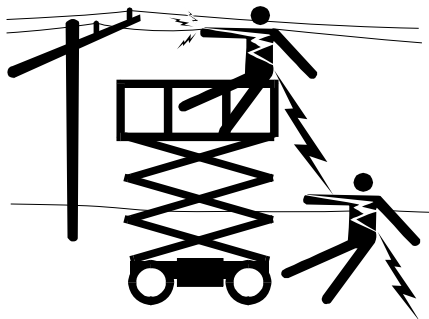

- Maintain safe clearance from electrical lines, apparatus, or any energized (exposed or insulated) parts in accordance with the Minimum Safe Approach Distance (MSAD) as specified in Table 1-1. Allow for machine movement and electrical line swaying.

Table 1-1. Minimum Safe Approach Distances (M.S.A.D.)

Voltage Range (Phase to Phase)	MINIMUM SAFE APPROACH DISTANCE in Feet (Meters)
0 to 50KV	10 (3)
Over 50 KV to 200 KV	15 (5)
Over 200KV to 350 KV	20 (6)
Over 350 KV to 500 KV	25 (8)
Over 500 KV to 750 KV	35 (11)
Over 750 KV to 1000 KV	45 (14)

**NOTE:** *This requirement shall apply except where employer, local or governmental regulations are more stringent.*

- Maintain a clearance of at least 10 ft. (3m) between any part of the machine and its occupants, their tools, and their equipment from any electrical line or apparatus carrying up to 50,000 volts. One foot additional clearance is required for every additional 30,000 volts or less.
- The minimum safe approach distance may be reduced if insulating barriers are installed to prevent contact, and the barriers are rated for the voltage of the line being guarded. These barriers shall not be part of (or attached to) the



machine. The minimum safe approach distance shall be reduced to a distance within the designed working dimensions of the insulating barrier. This determination shall be made by a qualified person in accordance with the employer, local, or governmental requirements for work practices near energized equipment.

### **⚠ DANGER**

**DO NOT MANEUVER MACHINE OR PERSONNEL INSIDE PROHIBITED ZONE (MSAD). ASSUME ALL ELECTRICAL PARTS AND WIRING ARE ENERGIZED UNLESS KNOWN OTHERWISE.**

### **Tipping Hazards**

- Ensure that the ground conditions are adequate to support the maximum tire load indicated on the tire load decals located on the chassis adjacent to each wheel. Do not travel on unsupported surfaces.
- The user should be familiar with the driving surface before driving. Do not exceed the allowable sideslope and grade while driving.

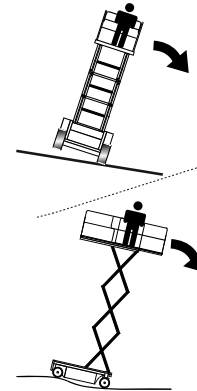

- Do not elevate platform or drive with platform elevated while on or near a sloping, uneven, or soft surface. Ensure machine is positioned on a firm, level and uniformly supported surface before elevating platform or driving with the platform in the elevated position.
- Before driving on floors, bridges, trucks, and other surfaces, check allowable capacity of the surfaces.
- Never exceed the maximum work load as specified on the platform. Keep all loads within the confines of the platform, unless authorized by JLG.

## SECTION 1 - SAFETY PRECAUTIONS

---

- Keep the chassis of the machine a minimum of 0.6m (2 ft) from holes, bumps, drop-offs, obstructions, debris, concealed holes, and other potential hazards at the ground level.
- Never attempt to use the machine as a crane. Do not tie-off machine to any adjacent structure. Never attach wire, cable, or any similar items to platform.
- Do not operate the machine when wind conditions exceed the maximum allowable wind speed.
- Do not cover the platform sides or carry large surface-area items in the platform when operating outdoors. The addition of such items increases the exposed wind area of the machine.
- Do not increase the platform size with unauthorized deck extensions or attachments.
- If scissor arm assembly or platform is caught so that one or more wheels are off the ground, all persons must be removed before attempting to free the machine. Use cranes, forklift trucks, or other appropriate equipment to stabilize machine and remove personnel.

### Crushing and Collision Hazards

- Approved head gear must be worn by all operating and ground personnel.

- Keep hands and limbs out of the scissor arm assembly during operation.
- Watch for obstructions around machine and overhead when driving. Check clearances above, on sides, and bottom of platform when lifting or lowering platform.

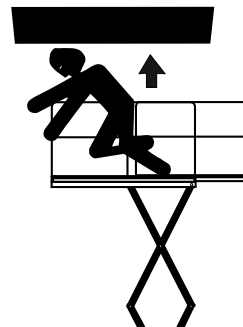

- During operation, keep all body parts inside platform railing.
- Always post a lookout when driving in areas where vision is obstructed.
- Keep non-operating personnel at least 1.8m (6 ft) away from machine during all driving operations.
- Under all travel conditions, the operator must limit travel speed according to conditions of ground surface, congested areas, and other factors.

tion, visibility, slope, location of personnel, and other factors causing hazards of collision or injury to personnel.

- Be aware of stopping distances in all drive speeds. When driving in high speed, switch to low speed before stopping. Travel grades in low speed only.
- Do not use high speed drive in restricted or close quarters or when driving in reverse.
- Exercise extreme caution at all times to prevent obstacles from striking or interfering with operating controls and persons in the platform.
- Ensure that operators of other overhead and floor level machines are aware of the aerial work platform's presence. Disconnect power to overhead cranes. Barricade floor area if necessary.
- Avoid operating over ground personnel. Warn personnel not to work, stand, or walk under a raised platform. Position barricades on floor as necessary.

### 1.4 TOWING, LIFTING, AND HAULING

- Never allow personnel in platform while towing, lifting, or hauling.
- This machine should not be towed, except in the event of emergency, malfunction, power failure, or loading/unloading. Refer to emergency towing procedures.
- Ensure platform is fully retracted and completely empty of tools prior to towing, lifting or hauling.
- When lifting machine with a forklift, position forks only at designated areas of the machine. Lift with a forklift of adequate capacity.
- Refer to Section 4 for lifting information.

### 1.5 MAINTENANCE

#### General

This section contains general safety precautions which must be observed during maintenance of this machine. Additional precautions to be observed during machine maintenance are inserted at the appropriate points in this manual and in the Service and Maintenance Manual. It is of utmost importance that maintenance personnel pay strict attention to these precautions to avoid possible injury to personnel or damage to the machine or property. A maintenance program must be established by a

## SECTION 1 - SAFETY PRECAUTIONS

---

qualified person and must be followed to ensure that the machine is safe.

### Maintenance Hazards

- Shut off power to all controls and ensure that all operating systems are secured from inadvertent motion prior to performing any adjustments or repairs.
- Never work under an elevated platform until it has been fully lowered to the full down position, if possible, or otherwise supported and restrained from movement with appropriate safety props, blocking, or overhead supports.
- Always relieve hydraulic pressure from all hydraulic circuits before loosening or removing hydraulic components.
- Always disconnect batteries when servicing electrical components or when performing welding on the machine.
- Shut down the engine (if equipped) while fuel tanks are being filled.
- Ensure replacement parts or components are identical or equivalent to original parts or components.
- Never attempt to move heavy parts without the aid of a mechanical device. Do not allow heavy objects to rest in an unstable position. Ensure adequate support is provided when raising components of the machine.

- Remove all rings, watches, and jewelry when performing any maintenance. Do not wear loose fitting clothing or long hair unrestrained which may become caught or entangled in equipment.
- Use only clean approved non-flammable cleaning solvents.
- Never alter, remove, or substitute any items such as counterweights, tires, batteries, platforms or other items that may reduce or affect the overall weight or stability of the machine.
- Reference the Service and Maintenance Manual for the weights of critical stability items.

### **WARNING**

**MODIFICATION OR ALTERATION OF AN AERIAL WORK PLATFORM SHALL BE MADE ONLY WITH PRIOR WRITTEN PERMISSION FROM THE MANUFACTURER.**

### Battery Hazards

- Always disconnect batteries when servicing electrical components or when performing welding on the machine.
- Do not allow smoking, open flame, or sparks near battery during charging or servicing.
- Do not contact tools or other metal objects across the battery terminals.

- Always wear hand, eye, and face protection when servicing batteries. Ensure that battery acid does not come in contact with skin or clothing.

 **WARNING**

**BATTERY FLUID IS HIGHLY CORROSIVE. AVOID CONTACT WITH SKIN AND CLOTHING AT ALL TIMES. IMMEDIATELY RINSE ANY CONTACTED AREA WITH CLEAN WATER AND SEEK MEDICAL ATTENTION.**

- Charge batteries only in a well ventilated area.
- Avoid overfilling the battery fluid level. Add distilled water to batteries only after the batteries are fully charged.



## **SECTION 2. USER RESPONSIBILITIES, MACHINE PREPARATION AND INSPECTION**

### **2.1 PERSONNEL TRAINING**

The aerial platform is a personnel handling device; so it is necessary that it be operated and maintained only by trained personnel.

Persons under the influence of drugs or alcohol or who are subject to seizures, dizziness or loss of physical control must not operate this machine.

#### **Operator Training**

Operator training must cover:

1. Use and limitations of the controls in the platform and at the ground, emergency controls and safety systems.
2. Control labels, instructions, and warnings on the machine.
3. Rules of the employer and government regulations.
4. Use of approved fall protection equipment.
5. Enough knowledge of the mechanical operation of the machine to recognize a malfunction or potential malfunction.

6. The safest means to operate the machine where overhead obstructions, other moving equipment, and obstacles, depressions, holes, drop-offs.
7. Means to avoid the hazards of unprotected electrical conductors.
8. Specific job requirements or machine application.

#### **Training Supervision**

Training must be done under the supervision of a qualified person in an open area free of obstructions until the trainee has developed the ability to safely control and operate the machine.

#### **Operator Responsibility**

The operator must be instructed that he/she has the responsibility and authority to shut down the machine in case of a malfunction or other unsafe condition of either the machine or the job site.

## **2.2 PREPARATION, INSPECTION, AND MAINTENANCE**

The following table covers the periodic machine inspections and maintenance recommended by JLG Industries, Inc. Consult local regulations for further requirements for aerial work platforms. The frequency of inspections and maintenance must be increased as necessary when the machine is used in a harsh or hostile environment, if the machine is used with increased frequency, or if the machine is used in a severe manner.

### **NOTICE**

JLG INDUSTRIES, INC. RECOGNIZES A FACTORY-CERTIFIED SERVICE TECHNICIAN AS A PERSON WHO HAS SUCCESSFULLY COMPLETED THE JLG SERVICE TRAINING SCHOOL FOR THE SPECIFIC JLG PRODUCT MODEL.



## SECTION 2 - USER RESPONSIBILITIES, MACHINE PREPARATION AND INSPECTION

**Table 2-1. Inspection and Maintenance Table**

Type	Frequency	Primary Responsibility	Service Qualification	Reference
Pre-Start Inspection	Before using each day; or whenever there's an Operator change.	User or Operator	User or Operator	Operator and Safety Manual
Pre-Delivery Inspection (See Note)	Before each sale, lease, or rental delivery.	Owner, Dealer, or User	Qualified JLG Mechanic	Service and Maintenance Manual and applicable JLG inspection form
Frequent Inspection (See Note)	In service for 3 months or 150 hours, whichever comes first; or Out of service for a period of more than 3 months; or Purchased used.	Owner, Dealer, or User	Qualified JLG Mechanic	Service and Maintenance Manual and applicable JLG inspection form
Load Sensing System Verification	Semi Annually	Owner, Dealer, or User	Factory Certified Service Technician (Recommended)	Operator and Safety Manual
Annual Machine Inspection (See Note)	Annually, no later than 13 months from the date of prior inspection.	Owner, Dealer, or User	Factory Certified Service Technician (Recommended)	Service and Maintenance Manual and applicable JLG inspection form
Preventative Maintenance	At intervals as specified in the Service and Maintenance Manual.	Owner, Dealer, or User	Qualified JLG Mechanic	Service and Maintenance Manual

**NOTE:** *Inspection forms are available from JLG. Use the Service and Maintenance Manual to perform inspections.*

## SECTION 2 - USER RESPONSIBILITIES, MACHINE PREPARATION AND INSPECTION

### 2.3 PRE-START INSPECTION

The Pre-Start Inspection should include each of the following:

1. **Cleanliness** – Check all surfaces for leakage (oil, fuel, or battery fluid) or foreign objects. Report any leakage to the proper maintenance personnel.
2. **Structure** - Inspect the machine structure for dents, damage, weld or parent metal cracks or other discrepancies.

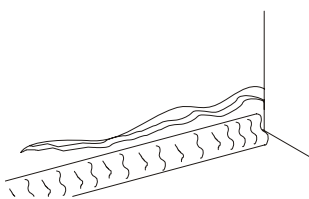

Parent Metal Crack

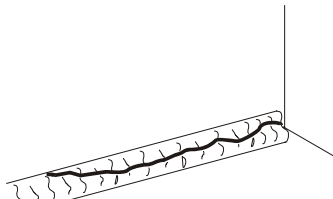

Weld Crack

3. **Decals and Placards** – Check all for cleanliness and legibility. Make sure none of the decals and placards are missing. Make sure all illegible decals and placards are cleaned or replaced.

4. **Operators and Safety Manuals** – Make sure a copy of the Operator and Safety Manual is enclosed in the weather resistant storage container.
5. **“Walk-Around” Inspection** – Refer to Figure 2-1.
6. **Battery** – Charge as required.
7. **Fuel** - (Combustion Engine Powered Machines) – Add the proper fuel as necessary.
8. **Engine Oil Supply** - Ensure that the engine oil level is at the full mark on the dipstick and the filler cap is secure
9. **Fluid Levels** - Be sure to check the engine oil and the hydraulic oil levels.
10. **Accessories/Attachments** - Reference the Operator and Safety Manual of each attachment or accessory installed upon the machine for specific inspection, operation, and maintenance instructions.
11. **Function Check** – Once the “Walk-Around” Inspection is complete, perform a functional check of all systems in an area free of overhead and ground level obstructions. Refer to Section 4 for more specific instructions on the operation of each function.

### **WARNING**

**IF THE MACHINE DOES NOT OPERATE PROPERLY, TURN OFF THE MACHINE IMMEDIATELY! REPORT THE PROBLEM TO THE PROPER MAINTENANCE PERSONNEL. DO NOT OPERATE THE MACHINE UNTIL IT IS DECLARED SAFE FOR OPERATION.**

### **Function Check**

Perform the Function Check as follows:

1. From the ground control panel with no load in the platform:
  - a. Check that all function control switches and locks are in place.
  - b. Operate all functions and check all limiting and cut-out switches.
  - c. Check for proper lifting and lowering of the platform.
  - d. If the platform extension is extended, check that the extension retracts.

**NOTE:** *Be sure the platform extension is retracted before lowering.*

- e. Ensure that all machine functions are disabled when the Emergency Stop Button is activated.

- f. Check manual descent.
  - g. Check for proper lifting and lowering of the platform.
  - h. Check the function of the protective scissor cage.
2. From the platform control console:
    - a. Ensure that the control console is firmly secured in the proper location.
    - b. Check that all guards protecting the switches are in place.
    - c. Operate all functions
    - d. Check the high drive cut out switch by raising the platform by 3.5 m (11.5 ft) on the 210-25 and 3.7 m (12.1 ft) on the 245-25 and assure that the high drive speed is cut out.
    - e. Ensure that all machine functions are disabled when the Emergency Stop Button is pushed in.
    - f. Ensure that all LED's in the control box are working properly.
    - g. Check that the platform extension extends and retracts properly.

## **SECTION 2 - USER RESPONSIBILITIES, MACHINE PREPARATION AND INSPECTION**

---

- 3.** With the platform in the transport (stowed) position:
  - a.** Drive the machine on a level grade and stop to ensure the brakes hold.
  - b.** To ensure proper operation of the tilt sensor, drive the machine onto a tilt greater than the preset 3° and attempt to lift.

## SECTION 2 - USER RESPONSIBILITIES, MACHINE PREPARATION AND INSPECTION

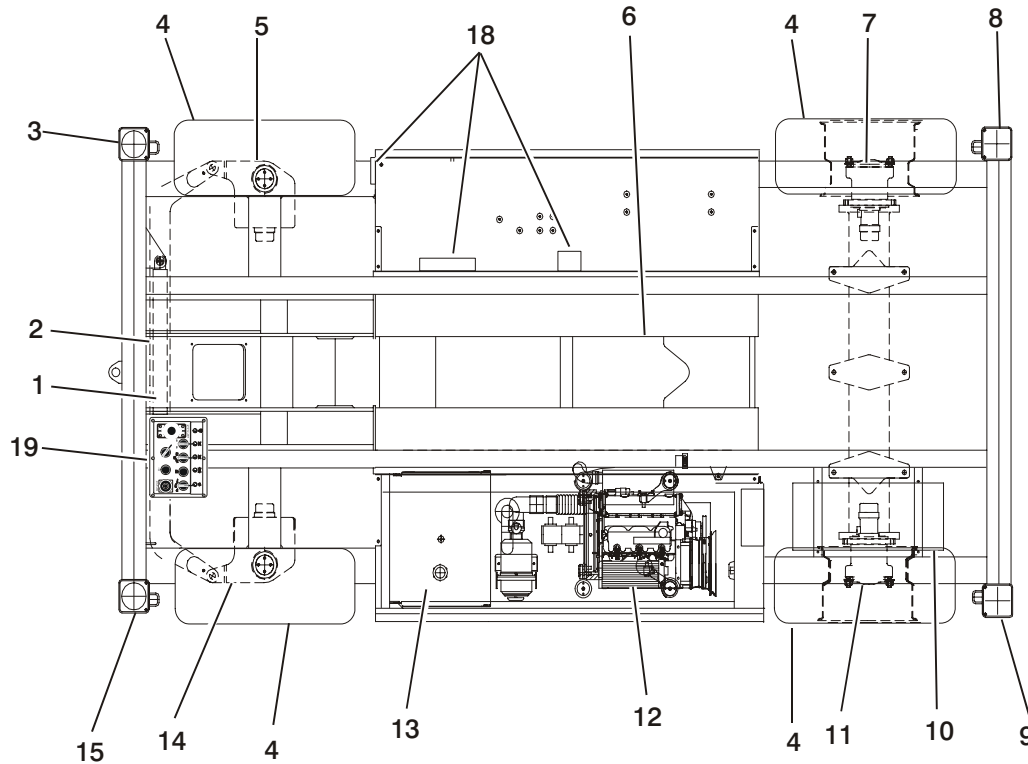

Figure 2-1. Walk - Around Inspection Diagram

## SECTION 2 - USER RESPONSIBILITIES, MACHINE PREPARATION AND INSPECTION

---

### General

Begin the “Walk-Around Inspection” at Item 1, as noted on the diagram. Continue to the right (counterclockwise viewed from top) checking each item in sequence for the conditions listed in the “Walk-Around Inspection Checklist”.

#### **⚠ WARNING**

**TO AVOID POSSIBLE INJURY, BE SURE MACHINE POWER IS “OFF” DURING “WALK-AROUND INSPECTION”.**

#### **NOTICE**

**DO NOT OVERLOOK VISUAL INSPECTION OF CHASSIS UNDERSIDE. CHECKING THIS AREA OFTEN RESULTS IN DISCOVERY OF CONDITIONS WHICH COULD CAUSE EXTENSIVE MACHINE DAMAGE.**

**NOTE:** *On each item, make sure there are no loose or missing parts, that they are securely fastened, and that no visible damage exists in addition to any other criteria mentioned.*

1. Steer Linkage - See Note.
2. Steer Cylinder - See Note

3. Outrigger - (right front) - See Note
4. Wheel and Tire Assembly - Properly secured, no missing lug nuts. Refer to Section 6. Inspect wheels for damage and corrosion.
5. Tie Rod and Spindle - (right front) - See Note
6. Lift Cylinder - See Note
7. Drive Hub, Right Rear - See Note
8. Outrigger - (right rear) - See Note
9. Outrigger - (left rear) - See Note
10. Fuel Tank - See Note
11. Drive Hub, Left Rear - See Note
12. Motor and Hydraulic Pump Assembly - Check engine oil level. See Note

**Figure 2-2. Walk - Around Inspection Points (Sheet 1)**

## **SECTION 2 - USER RESPONSIBILITIES, MACHINE PREPARATION AND INSPECTION**

---

13. Hydraulic Reservoir - Recommended hydraulic fluid level on level indicator on tank. Breather cap secure and working.
14. Tie Rod and Spindle - (left front) - See Note
15. Outrigger - (left front) - See Note
16. Scissor Arms and Sliding Wear Pads (Not Shown) - See Note
17. Control Valve - No unsupported wires or hoses; no damaged or broken wires.
18. Ground Controls - Placard secure and legible, control switches return to neutral position, emergency stop switch functions properly.
19. Platform Control Console (mounted on platform rail) - Placard secure and legible, control lever and switches return to neutral, trigger switch and emergency stop switch function properly, operation and safety manual in storage box.
20. Platform/Handrail Installation (Not Shown) - See Note

**Figure 2-3. Walk - Around Inspection Points (Sheet 2)**





## **SECTION 3. USER RESPONSIBILITIES AND MACHINE CONTROL**

### **3.1 GENERAL**

#### **NOTICE**

**SINCE THE MANUFACTURER HAS NO DIRECT CONTROL OVER MACHINE APPLICATION AND OPERATION, CONFORMANCE WITH GOOD SAFETY PRACTICES IN THESE AREAS IT IS THE RESPONSIBILITY OF THE USER AND HIS OPERATING PERSONNEL.**

This section provides the necessary information needed to understand control functions. Included in this section are the operating characteristics and limitations, and functions and purposes of controls and indicators. It is important that the user read and understand the proper procedures before operating the machine. These procedures will aid in obtaining optimum service life and safe operation.

### **3.2 PERSONNEL TRAINING**

The scissor lift is a personnel handling device; therefore, it is essential that it be operated and maintained only by authorized personnel who have demonstrated that they understand the proper use and maintenance of the machine. It is important that all personnel who are assigned to and responsible for the operation and maintenance of the machine undergo a thorough training program and check out period

in order to become familiar with the characteristics prior to operating the machine.

Persons under the influence of drugs or alcohol or who are subject to seizures, dizziness or loss of physical control must not be permitted to operate the machine.

### **Operator Training**

Operator training must include instruction in the following:

1. Use and limitations of the platform controls, ground controls, emergency controls and safety systems.
2. Knowledge and understanding of this manual and of the control markings, instructions and warnings on the machine itself.
3. Knowledge and understanding of all safety work rules of the employer and of Federal, State and Local Statutes, including training in the recognition and avoidance of potential hazards in the work place; with particular attention to the work to be performed.
4. Proper use of all required personnel safety equipment.
5. Sufficient knowledge of the mechanical operation of the machine to recognize a malfunction or potential malfunction.

## SECTION 3 - USER RESPONSIBILITIES AND MACHINE CONTROL

---

6. The safest means to operate near overhead obstructions, other moving equipment, obstacles, depressions, holes, drop-offs, etc. on the supporting surface.
7. Means to avoid the hazards of unprotected electrical conductors.
8. Any other requirements of a specific job or machine application.

### Training Supervision

Training must be done under the supervision of a qualified operator or supervisor in an open area free of obstructions until the trainee has developed the ability to safely control a scissor lift in congested work locations.

### Operator Responsibility

The operator must be instructed that he has the responsibility and authority to shut down the machine in case of a malfunction or other unsafe condition of either the machine or the job site and to request further information from his supervisor or JLG Distributor before proceeding.

## 3.3 OPERATING CHARACTERISTICS AND LIMITATIONS

### General

A thorough knowledge of the operating characteristics and limitations of the machine is always the first requirement for any user, regardless of user's experience with similar types of equipment.

### Placards

Important points to remember during operation are provided at the control stations by **DANGER, WARNING, CAUTION, IMPORTANT** and **INSTRUCTION** placards. This information is placed at various locations for the express purpose of alerting personnel of potential hazards constituted by the operating characteristics and load limitations of the machine. See foreword for definitions of the above placards.

## **Capacities**

Raising platform above the stowed position with or without any load in platform, is based on the following criteria:

1. Machine is level and positioned on a firm supporting surface.
2. Load is within manufacturer's rated capacity.
3. All machine systems are functioning properly.

## **3.4 CONTROLS AND INDICATORS**

### **Ground Control Stations**

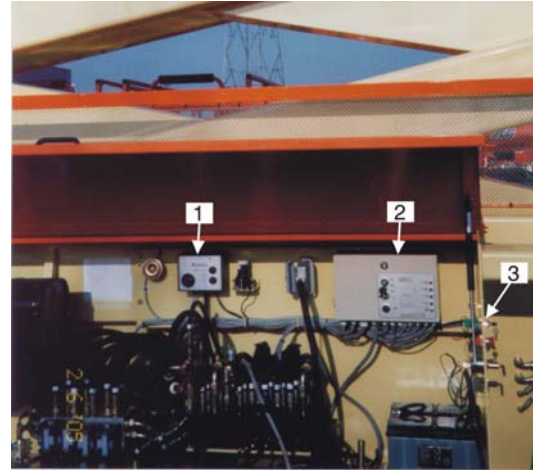

1. Engine Control

3. Power Outrigger

2. Platform/Ground Control

**Figure 3-1. Ground Control Stations**

## SECTION 3 - USER RESPONSIBILITIES AND MACHINE CONTROL

### Engine Control

#### **⚠ WARNING**

**DO NOT OPERATE FROM GROUND CONTROL STATION WITH PERSONNEL IN THE PLATFORM EXCEPT IN AN EMERGENCY. PERFORM AS MANY PRE-OPERATIONAL CHECKS AND INSPECTIONS FROM THE GROUND CONTROL STATION AS POSSIBLE.**

1. Start Assist - This push button is used to help assist starting the machine in cold temperatures. (overrides 6 second crank limit of Engine Start Button)
2. Engine Start - A push button switch that, when depressed, will start the engine. (crank time limited to 6 seconds before power supply required recycling)
3. Hourmeter - A meter used to measure the amount of time the machine is in use.

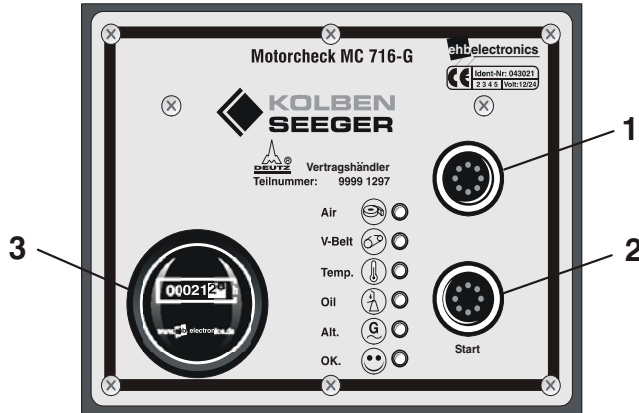

1. Start Assist
2. Engine Start
3. Hourmeter

**Figure 3-2. Engine Control**

## Platform Ground Control

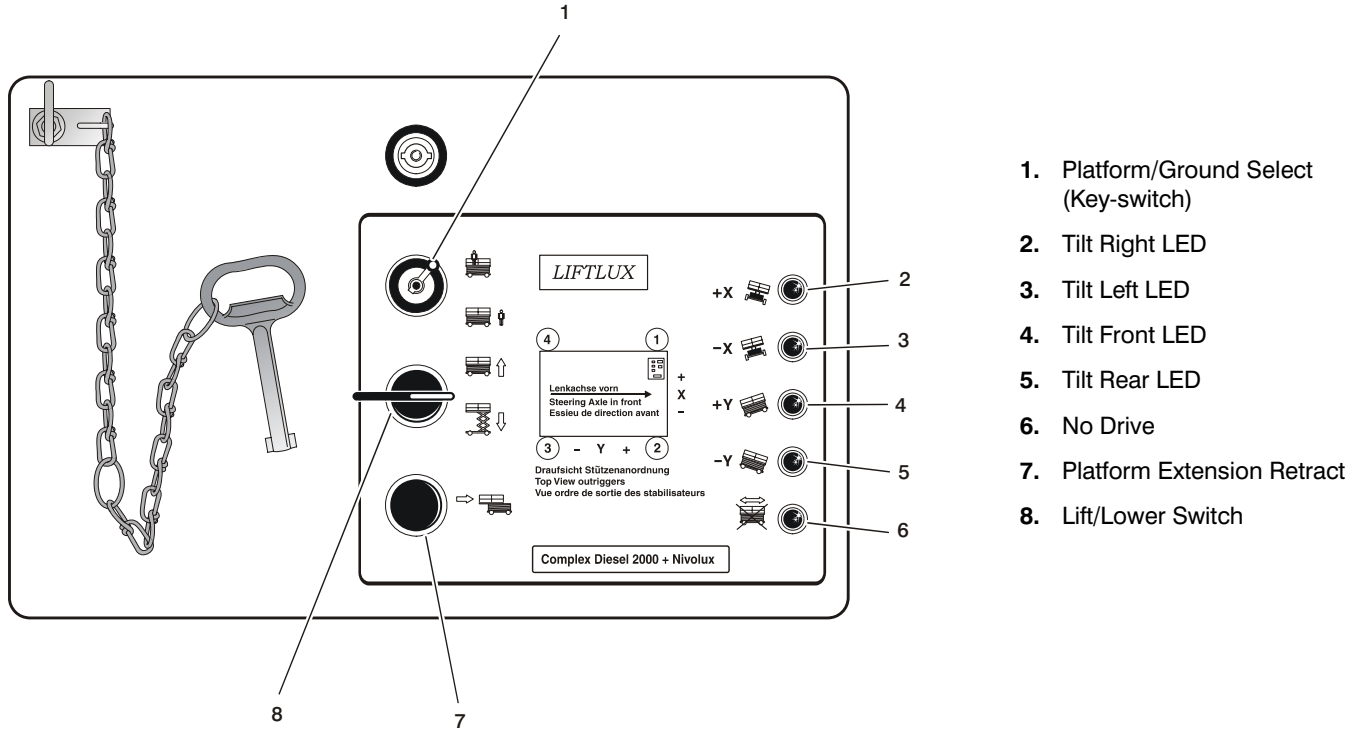

Figure 3-3. Platform Ground Control

## SECTION 3 - USER RESPONSIBILITIES AND MACHINE CONTROL

---

1. Platform/Ground Select - This three way keyswitch is used to select between platform controls or ground controls. When in the center position, the machine is disabled.
2. Tilt Right LED - This LED will illuminate any time the machine is tilted to the right.
3. Tilt Left LED - This LED will illuminate any time the machine is tilted to the left.
4. Tilt Front LED - This LED will illuminate any time the machine is tilted toward the machine front.
5. Tilt Rear LED - This LED will illuminate any time the machine is tilted toward the machine rear.
6. Drive Cutout LED - This LED is illuminated when the outriggers are used and the lift function is operated.
7. Platform Extension Retract - This push button switch is used to retract the platform deck extension if it is extended.

**NOTE:** *The platform deck extension should be retracted before lowering the platform.*

8. Lift Switch - This momentary switch is used to lift and lower the platform. The switch must be held for the duration of either lifting or lowering.

### Power Outrigger

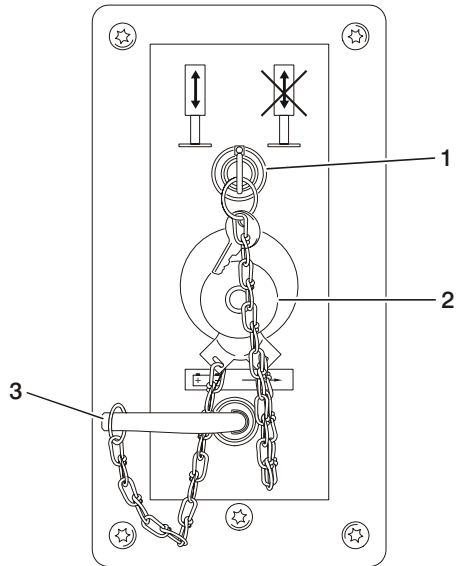

1. Outrigger Select Switch      3. Battery Isolator  
2. Emergency Stop Switch

**Figure 3-4. Power Outriggers**

1. Outrigger Select Switch - A three position key operated switch, allows the operator to select if outriggers are used or not. The center position will disable the machine.
2. Emergency Stop Switch - A two-position red mushroom-shaped emergency stop switch, when positioned to ON with the power selector switch positioned to ground, furnishes operating power to the ground control station. In addition, the switch can be used to turn off power to the function controls in the event of an emergency. Power is turned on by pulling the switch out (on), and is turned off by pushing the switch in (off).
3. Battery Isolator Switch - The battery isolator switch is located outside the battery compartment (chassis). Rotate handle counterclockwise to disconnect power from the battery.

### 3.5 PLATFORM CONTROL STATION

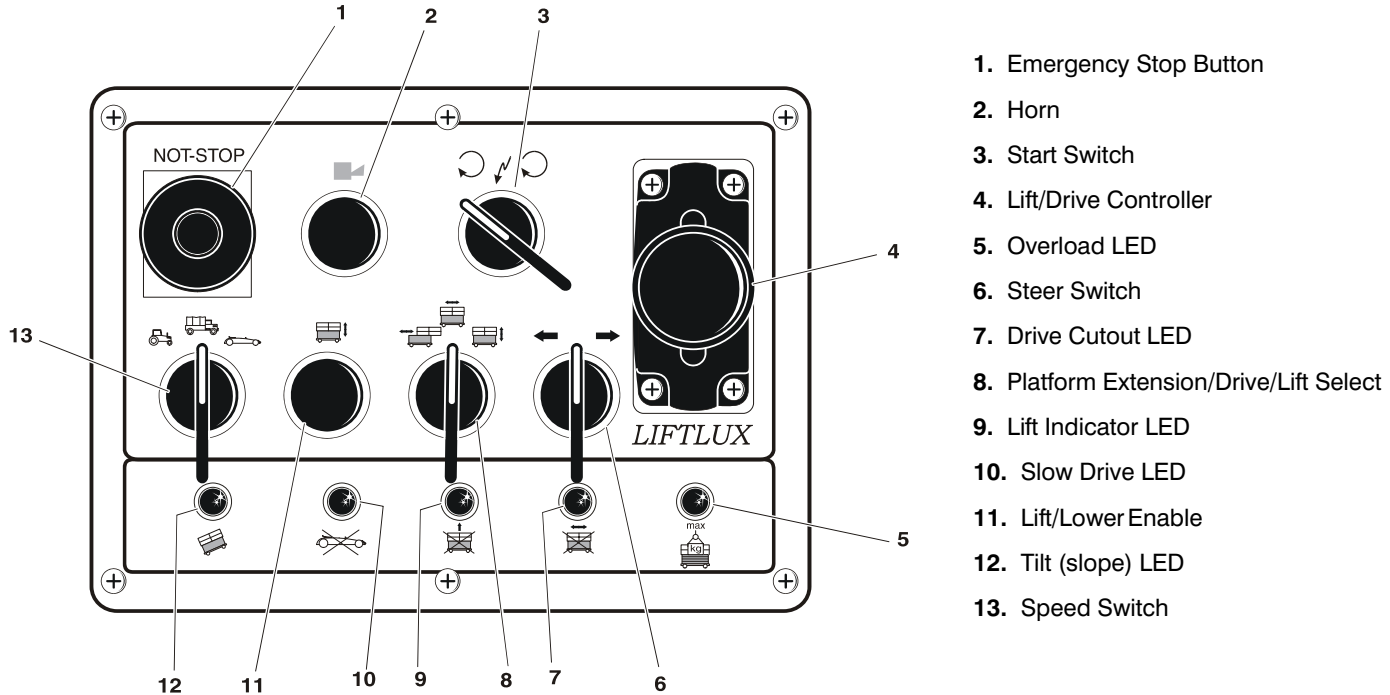

Figure 3-5. Platform Control Station



### Platform Control Descriptions

When platform/ground control select switch is switched to platform all movements and operations are controlled via the platform control panel. The controls are activated through either push-buttons or toggle switches, whose functions are marked with symbols and/or written text.

1. Emergency Stop Button - Button, when depressed, will immediately shut the machine off. Cuts out all functions except emergency platform lowering.
2. Horn - Button, when depressed, activates the horn.
3. Start Switch - Start the Diesel engine by turning the start switch on the control panel to the right.
4. Lift/Drive Controller - The controller works in conjunction with the platform extension, drive and the lift switch, depending upon which switch is selected.
5. Overload LED - This LED will illuminate (red) when the platform becomes overloaded.
6. Steer Switch - Choose the direction of steering by activating the steer button according to the direction symbols. This switch must be held for the duration of steering.
7. Drive LED - This LED light remains illuminated when the machine is in a drivable configuration.
8. Platform Extension/Drive/Lift Select - Switch that selects the functions of platform extension, drive, or lift.
9. Lift Indicator LED - LED light remains illuminated until the maximum height is reached.
10. Slow Drive LED - LED light remains illuminated when the machine is in slow drive speed mode.
11. Lift/Lower Enable - This switch works in conjunction with the lift/lower function. It must be depressed once after selecting the lift/lower direction.
12. Tilt (slope) LED - This LED light will remain on until the machine is driven on a slope greater than 3°. Once the tilt limit is exceeded the light will go out.

## SECTION 3 - USER RESPONSIBILITIES AND MACHINE CONTROL

---

13. Speed Switch - This switch allows you to choose between three different speeds:

**NOTE:** Only slow drive is possible when the machine is in the elevated position. When the platform reaches a height of 21 m (69 ft), the drive function is cut out.

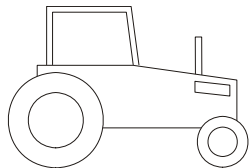

**Differential Lock 4x4** (tractor symbol) - The rotary switch must be held in the Differential lock position for the duration of the function.

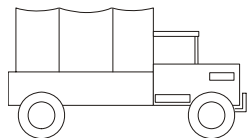

**Low Drive 4x4** (truck symbol)

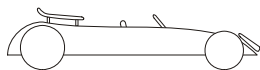

**High Drive 4x4** (race car symbol)

After selecting the desired speed, move the controller forward or backward depending upon the direction you want to travel.

**NOTE:** Tight turns are not possible while differential lock is activated.



## SECTION 3 - USER RESPONSIBILITIES AND MACHINE CONTROL

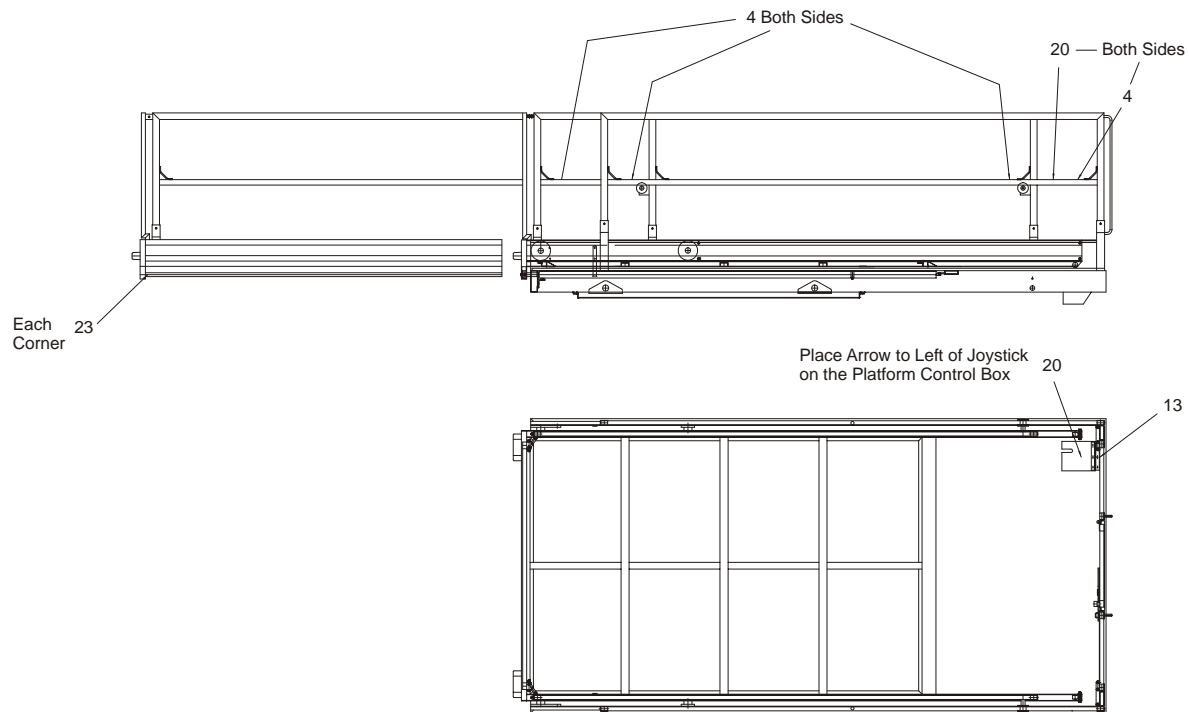

Figure 3-7. Decal Location - Sheet 2 of 3

## SECTION 3 - USER RESPONSIBILITIES AND MACHINE CONTROL

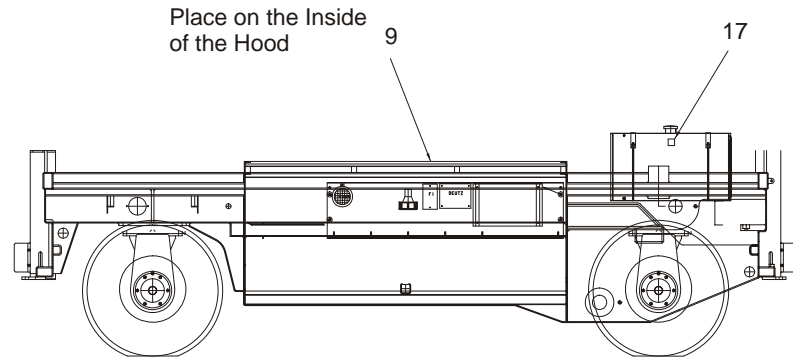
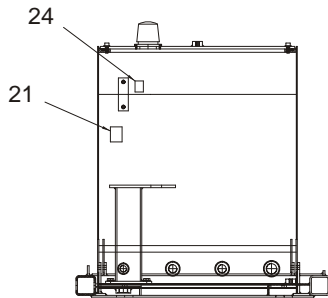
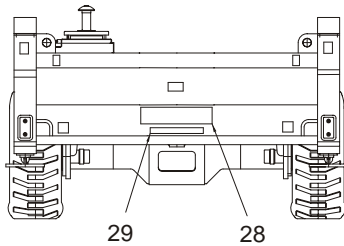

Figure 3-8. Decal Location - Sheet 3 of 3

## SECTION 3 - USER RESPONSIBILITIES AND MACHINE CONTROL

**Table 3-1. Decal Legend**

Item #	210-25 (0274682-C)	245-25 (0274582-C)
1	1701785	1701785
2	1703811	1703811
3	1703814	1703814
4	1704277	1704277
5	1705671	1705671
6	1705673	1705673
7	1706473	1706474
8	1706472	1706472
9	1706490	1706490
10	1706482	1706482
11	1706562	1706508
12	1706563	1706507
13	1706485	1706485
14	1706512	1706512
15	1706487	1706487
16	1706564	1706498
17	1701505	1701505

**Table 3-1. Decal Legend**

Item #	210-25 (0274682-C)	245-25 (0274582-C)
18	1701509	1701509
19	1703687	1703687
20	1703819	1703819
21	1704412	1704412
22	--	--
23	4420051	4420051
24	1703812	1703812
25 - 27	--	--
28	1702773	1702773
29	1704885	1704885
30	1705515	1705515

## **SECTION 4. MACHINE OPERATION**

### **4.1 DESCRIPTION**

#### **General Description of the Functions and Components.**

The normal location to operate the machine is on the platform. However, the control box can be disconnected from the platform location and plugged in (in emergencies) at the distribution terminal inside the valve compartment of the machine.



Situated on the control panel is an emergency STOP-button, which is activated when being pressed and cuts out all functions, except emergency lowering.

The machine is equipped with a horn. The horn is activated by a push-button located on the control panel. The machine is also equipped with an audible alarm, which is automatically activated, when the machine driven.

The allowable operation of the machine is within the following certain tolerance limits, which are monitored and controlled via limit switches:

#### **Tilt Switch**

The machine cannot be elevated or driven while elevated if it is on a slope greater than 3°. The grade of the slope is measured by a tilt switch, which cuts off the lift up, and elevated drive function. At this point lowering is still possible. The tilt switch is enabled when the platform is raised by approx. 1 m (3.2 ft).

The tilt switch cuts out lifting, driving, and steering once the machine reaches a tilt angle (slope) beyond 3° and the platform is raised by 1 m (3.2 ft). At this point, lowering is the only function possible.

## SECTION 4 - MACHINE OPERATION

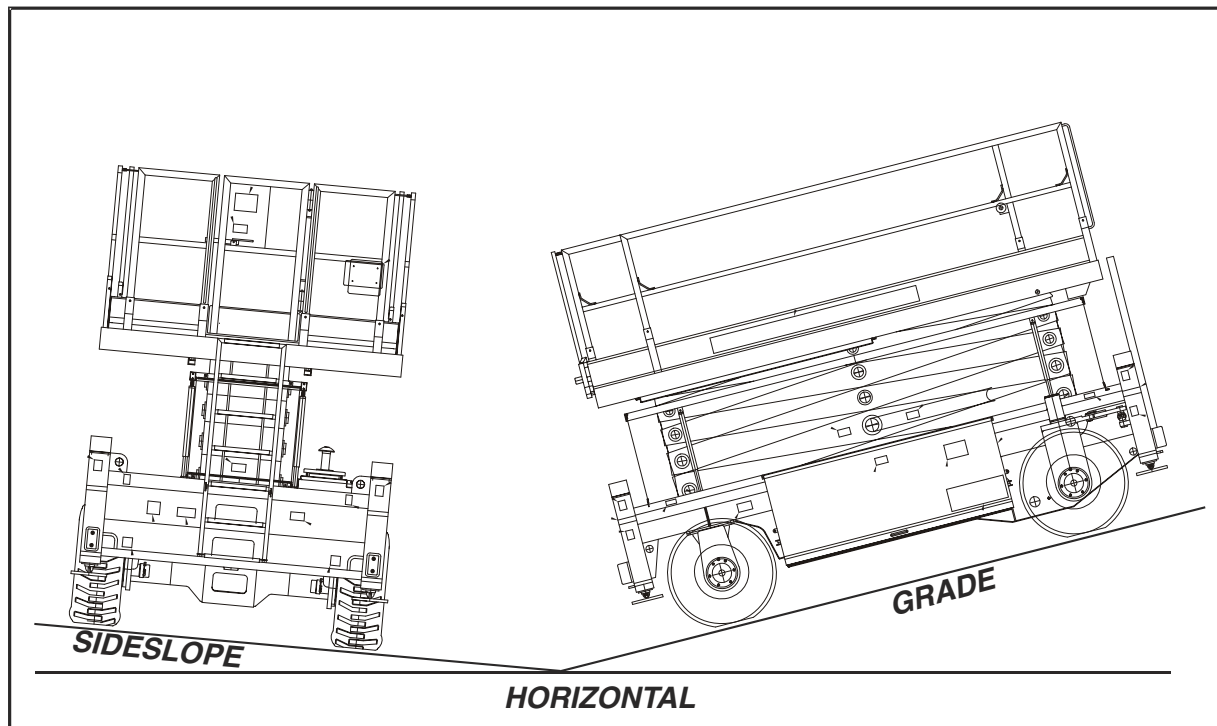

Figure 4-1. Grade and Sideslope



## High Drive Speed Cutout

When the platform is raised by 3.5 m (11.5 ft) on the 210-25 and 3.7 m (12.1 ft) on the 245-25, the high drive speed will be cut back to the low drive speed. Once the platform is completely lowered the high drive speed is possible.

## Maximum Height Cutout

If the platform has reached its maximum height, the lifting function will be cut off by the max. height limit switch.

## Maximum Drive Height Cutout

The maximum allowable drive height is 21 m (68.9 ft).

## Oscillating Axle Limit Switch

When the platform is raised above 3.5 m (11.5 ft) on the 210-25 and 3.7 m (12.1 ft) on the 245-25, and the axle inclination is  $>1^\circ$ , the drive function is cutout by a limit switch. When the platform is below 3.5 m (11.5 ft) on the 210-25 and 3.7 m (12.1 ft) on the 245-25, the inclination of the axle is ignored and driving is possible.

### CAUTION

**AS THE PROPER FUNCTIONING OF THE LIMIT SWITCHES IS VERY IMPORTANT FOR A SAFE USE OF THE MACHINE, THEIR FUNCTIONING HAS TO BE CHECKED DAILY BEFORE THE START OF THE OPERATION!**

- To make the check of the limit switches easy and convenient, test lights (LED's) for each limit switch are located on the platform control panel.

**NOTE:** *On all functions, other than the overload, the LED will illuminate when the function is working properly. The LED for the overload switch remains off until the platform becomes overloaded.*

## Platform Extend/Drive/Lift Select

- Also located at the platform control box is the platform extend/drive/lift select switch, which switches between the platform extend, drive and lift-lower mode. This means that platform extend, drive and lift/lower will be controlled by the same controller (joystick) depending on the position of the platform extend/drive/lift/lower select switch. The steering (left/right) will be controlled by a separate switch, which will be non active when the machine is in lift/lower mode.

## SECTION 4 - MACHINE OPERATION

### Load Sensing System (LSS)

The Load Sensing System (LSS) senses pressure in the main lift cylinder. If this pressure exceeds a pre-set level the following will occur:

1. The overload warning indicator on the platform control box will flash. (See the arrow below)

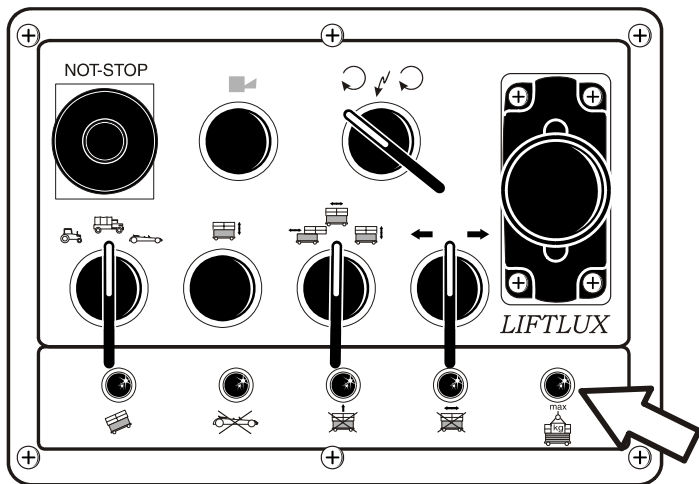

2. The audible warning will sound.
3. All normal movement will be prevented from both the platform control box and the ground control box.
4. Engaging the manual descent system, located in the valve compartment, will allow further movement.

### NOTICE

**IF ALL NORMAL MOVEMENT IS PREVENTED WITH NO AUDIBLE, OR VISUAL SIGNAL, THERE IS A FAULT IN THE SYSTEM.**

If this situation occurs, proceed as follows:

1. Return the platform to the retracted and lowered position by means of the manual descent system located in the valve compartment.
2. Disable the machine.
3. Have the fault assessed by a qualified JLG equipment service technician before returning to normal operation.

**NOTICE**

**THE LOAD SENSING SYSTEM MUST BE CALIBRATED WHEN ONE OR MORE OF THE FOLLOWING CONDITIONS OCCUR:**

- a. LSS component replacement.
- b. LSS Sensor removal or replacement.
- c. Platform is removed or replaced.

**NOTICE**

**THE LOAD SENSING SYSTEM REQUIRES PERIODIC FUNCTION VERIFICATION NOT TO EXCEED 6 MONTHS FROM PREVIOUS VERIFICATION. REFER TO TESTING AND EVALUATION IN SECTION 6.**

**4.2 OPERATION**

**NOTE:** *The platform control box can be plugged in at ground level inside the valve compartment.*

- There is an emergency stop switch positioned on the platform control box (red button) and one located ground level at the chassis. When activated, the signals of the control board will be cut off instantly and all functions will be stopped, except the functions emergency descent and emergency lifting (at ground level). These will still work if the emergency button at the control box is pressed.
- The Master Switch at the chassis acts as an isolator switch for the batteries and cuts off the power supply.
- The auto leveling outriggers can be turned on or off (Outrigger-Switch ON/OFF). This is a keyswitch which is located outside the hydraulic tank compartment. The activation of the outriggers is controlled by the lift select function. The lift up select allows the outriggers to extend. The lift down select allows the outriggers to retract.
- The machine is equipped with a horn, which can be activated from the control box. While driving, a constant acoustic signal is activated as an additional motion alarm.

### 4.3 LIFTING AND LOWERING

If the lift/drive-switch is in the lift position lifting/lowering will be activated by the joystick controller in conjunction with the enable button. After the joystick passes the neutral position the maximum lift speed is reached.

**NOTE:** *If the lift/drive-switch is in the drive position, the functions lift/lower are deactivated. The emergency lift/lower switch, located in the bottom chassis however still remains active. This switch can only be activated when the keyswitch is in the ground control position.*

**NOTE:** *With outriggers selected, the outriggers are part of the lift function, and the machine will not lift until the outriggers are deployed and the machine is level.*

#### CAUTION

**DO NOT LIFT DOWN WITHOUT COMPLETELY RETRACTING THE PLATFORM EXTENSION.**

**NOTE:** *The machine is equipped with gravity lift down. The engine does not need to be running to lower the platform.*

### 4.4 AUTOMATIC SELF LEVELING

The machine is equipped with an auto leveling feature that allows the operator to automatically level the machine. This function can be turned on or off at the ground control station.

With the auto leveling function selected, the outriggers are deployed by using the lift controller. Lift up will extend the outriggers and Lift down will retract the outriggers.

All outriggers must be extended and in contact with the support surface before the platform is lifted from the stowed position. If one or more outriggers, despite being fully extended, not be in contact with the support surface the outriggers must be retracted and the machine moved to a more appropriate position.

#### WARNING

**IF THE MACHINE BECOMES UNLEVEL, CAREFULLY LOWER THE PLATFORM AND REPOSITION THE MACHINE.**

**NOTE:** *The outriggers can not be used from the ground control station.*

When the automatic leveling system is activated, the drive function is cutout, the control lamps on the Nivelux-box show the results of the measurement and the outriggers start to

extend. At this stage the system solely controls the setting of the outriggers to level the chassis.

**NOTICE**

**ALWAYS BE SURE THAT THE OPERATING SURFACE THE MACHINE IS TO BE USED ON IS FIRM AND FREE OF ANY VOIDS OR OBSTRUCTIONS THAT MAY CAUSE THE OUTRIGGERS TO NOT PERFORM PROPERLY.**

To retract the outriggers activate the function "lowering" with the joystick. As soon as all outriggers are completely retracted the maximum hydraulic pressure will be reached at which time the machine will be okay to drive.

**4.5 DRIVING THE MACHINE FROM THE PLATFORM**

**WARNING**

To activate the drive of the machine, the controller (joystick) has to be moved forward for forward-drive and back for reverse-drive. The controller has a neutral zone of about  $\pm 7\%$  of the total possible moving distance. After reaching the end of the neutral zone, the valves "drive, brake and motion alarm" will be activated. The machine starts to move.

**4.6 STEERING**

The steer function is operated by activating the rotary steer switch in the direction indicated by the symbols on the control panel.

**4.7 HYDRAULIC PLATFORM EXTENSION**

With the lift/drive/extension switch in the extension position, the platform can be hydraulically extended. The function is activated by moving the controller forward to extend and backwards to retract.

**4.8 EMERGENCY LOWERING - MANUAL DESCENT**

All control switches have to be set to the neutral position. After that, the emergency lowering valve, which is located on the lift cylinder, can be opened hydraulically by a hand pump located inside the hydraulic compartment. Once the lowering is completed all levers of the emergency lowering function have to be put into the neutral position. Refer to Section 5, Emergency Procedures, for instructions on manual lowering.

### 4.9 PARKING AND STOWING

Once the work carried out is completed the machine has to be fully lowered and the battery isolator switch should be turned off.

#### **WARNING**

**THE MACHINE HAS TO BE LOCKED BY THE KEYSWITCH ON THE GROUND CONTROL PANEL SWITCH TO AVOID THE USE BY ANY UNAUTHORIZED PERSONNEL.**

In case the machine is not used for a longer period of time, the batteries should be charged once every two weeks due to the self discharge and power consumption of the machine at rest.

### 4.10 LIMIT SWITCHES & SAFETY DEVICES

1. Limit Switches for Drive Mode - High drive is possible, when the platform is lowered. When the platform is raised by 3.5 m (11.5 ft)(210-25) and 3.7 (12.1 ft)(245-25) or greater, only low drive is possible.
2. Outrigger Interlock - This switch allows the machine to be driven when all outriggers are completely retracted. The switch also prevents the machine from being lifted until the machine is level.
3. Tilt Switch - If the machine is exceeding a tilt angle of 3°, the platform cannot be elevated by 1 m (3.2 ft) or greater or if driving while elevated the drive function will be cut out.
4. Maximum Height Switch - The Maximum Height Switch cuts out the lift once the platform reaches 21m (69 ft).
5. Scissor Protection Cage - To avoid jamming of objects in the scissor device a protective cage is designed, which by means of struts will automatically be raised, once the platform elevates.

### 4.11 TIE DOWN/LIFT LUGS

#### Tie Down

When transporting the machine, the platform extension must be fully retracted and the platform fully lowered in the stowed position with the machine securely tied down to the truck or trailer deck. Refer to the tie down lugs in Figure 4-2., Lifting and Tie Down Location.

#### Lifting

If it becomes necessary to lift the machine, it is possible to do so from the lifting lugs located at the four corners of the machine. These lugs enable the machine to be lifted using cranes or suitable lifting devices

**NOTE:** *If lifting becomes necessary from the lifting lugs, JLG Industries Inc. recommends the use of a proper spreader bar and straps/chains to avoid damage to the machine. Cranes or other lifting devices must be capable of handling the weights listed in the Operating Specifications table in section 6 of this manual.*

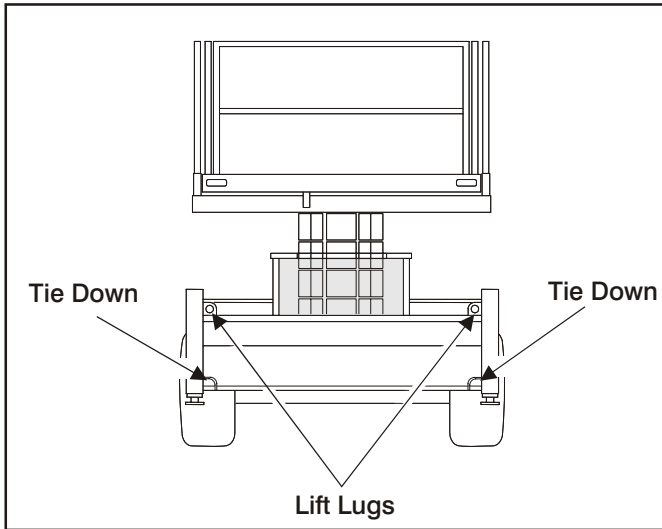
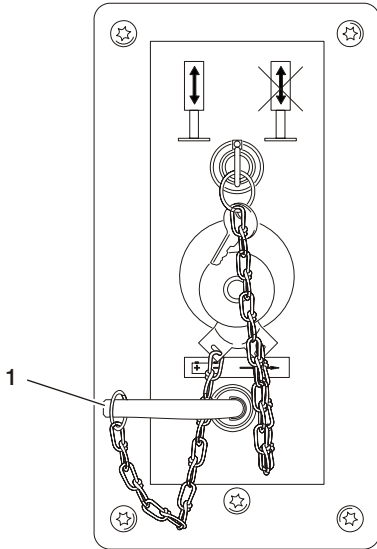

Figure 4-2. Lifting and Tie Down Location

## **4.12 TRANSPORT AND STORAGE OF THE MACHINE**

### **NOTICE**

**DURING TRANSPORT THE BATTERY ISOLATOR SWITCH SHOULD BE DISCONNECTED.**



**1.** Battery Isolator

The control box must be unplugged during the transport of the machine. The socket at the platform must be closed, whenever the control box is not plugged in. This is the best way to prevent any damages due to moisture and transport to the electrical components of the machine.

- Assure that the control box is stored in a safe and dry location and the main joystick controller is not affected by any harsh forces.



## **SECTION 5. EMERGENCY PROCEDURES**

### **5.1 GENERAL**

This section provides information on the procedures to be followed and on the systems and controls to be used in the event an emergency situation is encountered during machine operation. Prior to operation of the machine and periodically thereafter, the entire operating manual, including this section, should be reviewed by all personnel whose responsibilities include any work or contact with the machine.

#### **Emergency Stop Switch**

These large red buttons, one located outside the valve compartment and one at the Platform Control Station, will immediately stop the machine when depressed.

#### **NOTICE**

**CHECK MACHINE DAILY TO MAKE SURE EMERGENCY STOP BUTTON IS IN PLACE AND THAT GROUND CONTROL INSTRUCTIONS ARE IN PLACE AND LEGIBLE.**

#### **Platform Caught Overhead**

If the platform becomes jammed or snagged in overhead structures or equipment, do not continue operation of the machine from either the platform or the ground until the operator and all personnel are safely moved to a secure location. Only then should an attempt be made to free the platform using any necessary equipment and personnel. Do not operate controls to cause one or more wheels to leave the ground.

#### **Righting of Tipped Machine**

A forklift of suitable capacity or equivalent equipment should be placed under the elevated side of the chassis, with a crane or other suitable lifting equipment used to lift the platform while the chassis is lowered by the forklift or other equipment.

#### **Post-Incident Inspection**

Following any incident, thoroughly inspect the machine and test all functions first from the ground controls, then from the platform controls. Do not lift above 3 m (10 ft) until you are secure that all damage has been repaired, if required, and that all controls are operating correctly.

### 5.2 EMERGENCY OPERATION

#### Use of Ground Controls

#### NOTICE

**KNOW HOW TO USE THE GROUND CONTROLS IN AN EMERGENCY SITUATION.**

Ground personnel must be thoroughly familiar with the machine operating characteristics and the ground control functions. Training should include operation of the machine, review and understanding of this section and hands-on operation of the controls in simulated emergencies.

#### Operator Unable to Control Machine

1. Operate the machine from ground controls **ONLY** with the assistance of other personnel and equipment (cranes, overhead hoists, etc.) as may be required to safely remove the danger or emergency condition.
2. Other qualified personnel on the platform may use the platform controls. **DO NOT CONTINUE OPERATION IF CONTROLS DO NOT FUNCTION NORMALLY.**
3. Cranes, forklift trucks or other equipment which may be available are to be used to remove platform occupants

and stabilize motion of the machine in case machine controls are inadequate or malfunction when used.

### 5.3 MANUAL DESCENT

**NOTE:** *The manual descent system is provided as an emergency means to lower personnel from the platform.*

1. Locate the valve block inside the hydraulic cover on the right side of the machine
2. Turn valve knob clockwise until tight..

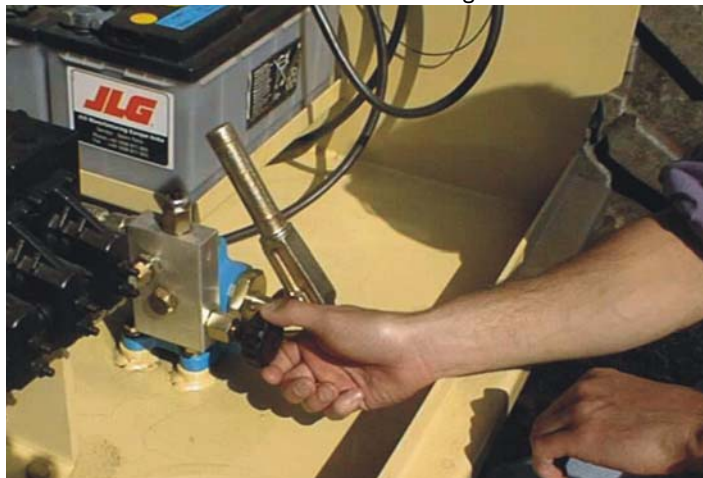

3. Locate the lever at the end of the valve bank near the back. Lift lever to engage valve.

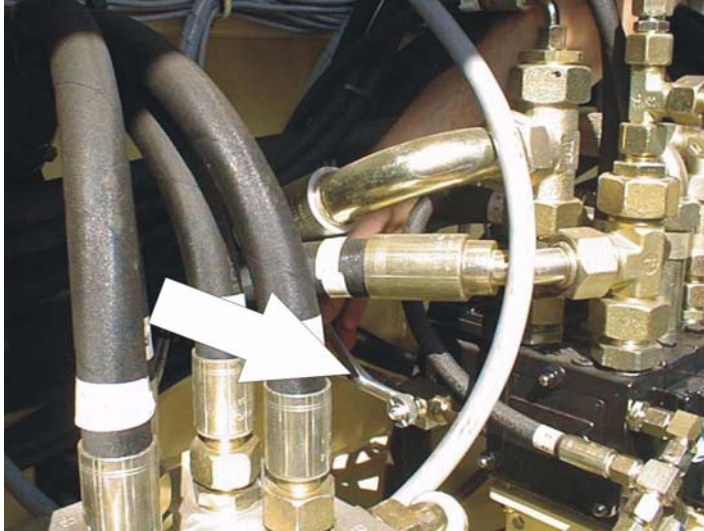

4. Locate handle and place it on the third valve from the left. Press handle downward while activating the manual pump.

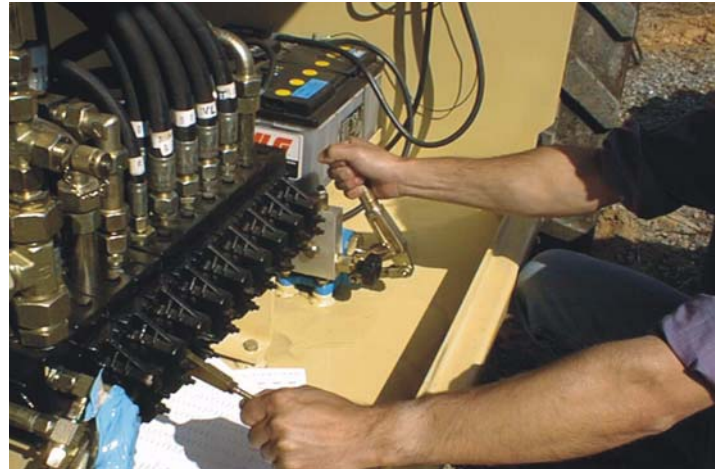

### **⚠ WARNING**

**PLATFORM WILL CONTINUE TO DESCEND ONCE MOVEMENT IS STARTED. TO STOP PLATFORM DESCENT, TURN VALVE KNOB COUNTERCLOCKWISE.**

5. After manual lowering is complete, release valve on the valve bank and remove handle from valve. Turn the valve on the hand pump counterclockwise to open and push pump handle forward. Push the lever at the end of the valve bank back to the original position.

## SECTION 5 - EMERGENCY PROCEDURES

---

### Manual Platform Deck Retraction

1. *The platform deck extension should be retracted before the platform lowering begins.*
2. Locate separate valve handle and place on the valve as shown (first section from the left).

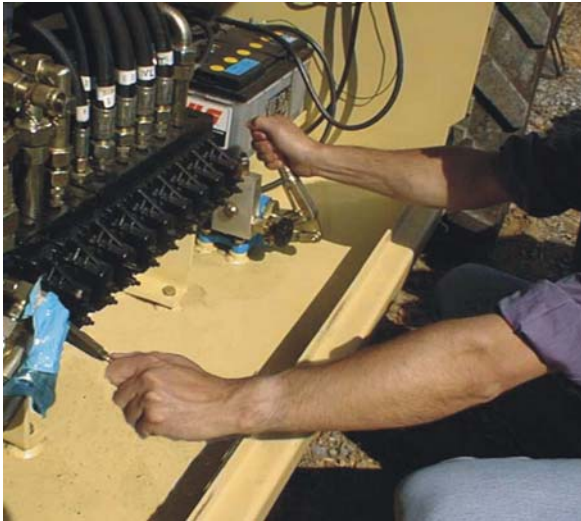

3. Open valve by pulling handle down.

4. While continuing to hold the valve open, activate the manual pump by pumping back and fourth as shown.
5. After manual platform deck retraction is complete, release valve on the valve bank and remove handle from valve. Turn the valve on the hand pump counterclockwise to open and push pump handle forward

### 5.4 EMERGENCY TOWING

#### **⚠ WARNING**

RUNAWAY VEHICLE/MACHINE HAZARD. MACHINE HAS NO TOWING BRAKES. TOWING VEHICLE MUST BE ABLE TO CONTROL MACHINE AT ALL TIMES. ON-HIGHWAY TOWING NOT PERMITTED. FAILURE TO FOLLOW INSTRUCTIONS COULD CAUSE SERIOUS INJURY OR DEATH.

MAXIMUM TOWING SPEED 5 M.P.H. (8 K.M.H.) FOR NO LONGER THAN 30-45 MINUTES.

MAXIMUM TOWING GRADE 25%.

#### **Prior to Towing**

Prior to towing the machine, complete the following:

#### **⚠ CAUTION**

DO NOT TOW MACHINE WITH ENGINE OPERATING OR DRIVE HUBS ENGAGED.

1. Completely lower platform.
2. Disconnect drive hubs by inverting disconnect cap. (See Figure 5-1.) After towing the machine, complete the following:

- a. Reconnect drive hubs by inverting disconnect cap. (See Figure 5-1.)

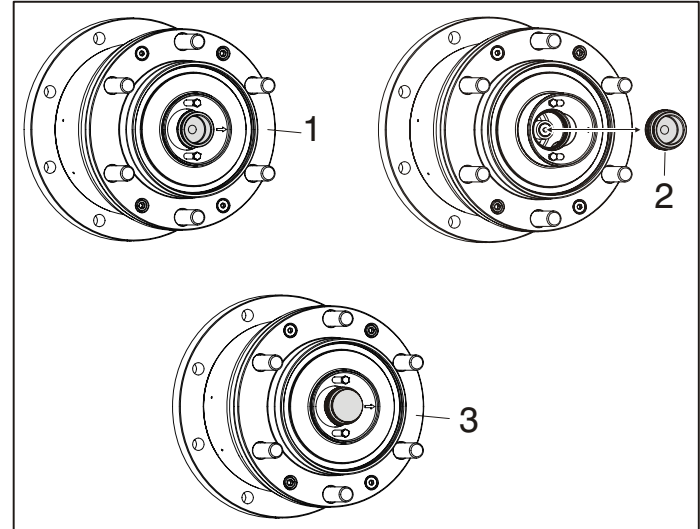

1. Hub Connected
2. Disconnect Cap
3. Hub Disconnected

**Figure 5-1. Drive Disconnect Hub**

### **Incident Notification**

It is imperative that JLG Industries, Inc. be notified immediately of any incident involving a JLG product. Even if no injury or property damage is evident, JLG should be contacted by telephone and provided with all necessary details at:

USA - 877-JLG-SAFE (877-554-7233)

Europe - 240-420-2661

It should be noted that failure to notify the Manufacturer of an incident involving a JLG Industries product within 48 hours of such an occurrence may void any warranty consideration on that particular machine.

## SECTION 6. GENERAL SPECIFICATIONS AND OPERATOR MAINTENANCE

### 6.1 INTRODUCTION

This section of the manual provides additional necessary information to the operator for proper operation and maintenance of this machine.

The maintenance portion of this section is intended as information to assist the machine operator to perform daily maintenance tasks only, and does not replace the more thorough Preventive Maintenance and Inspection Schedule included in the Service and Maintenance Manual.

**Other Publications Available Specific to this Machine:**

Service and Maintenance Manual .....	3121304
Illustrated Parts Manual .....	3121305

## SECTION 6 - GENERAL SPECIFICATIONS AND OPERATOR MAINTENANCE

### 6.2 OPERATING SPECIFICATIONS

Table 6-1. Operating Specifications

Description	210-25	245-25
Maximum Working Height	23 m (75 ft)	26.5 m (87 ft)
Maximum Platform Height	21 m (69 ft)	24.5 m (80 ft)
Turning Radius Inside Outside	1.5 m (4.9 ft) 6.2 m (20.3 ft)	
Wheelbase	3.9 m (12.8 ft)	3.9 m (12.8 ft)
Max Work Load (Capacity) - Main Platform/Platform Extension	1000/800kg (2205/1764 lb)	750 kg (1650 lb)
Maximum Occupants	5	2
Tools and Equipment	600/400 kg (1323/882 lbs)	590 kg (1300 lb)
Maximum Horizontal Manual Side Force	400 N (90 Lbf)	
Maximum Inclination	3°	
Maximum Operating Wind Speed	12.5 m/s (28mph)	
Gross Machine Weight (Approximate)	15,000 kg (33,069 lbs)	16,800 kg (37,038 lb)

Table 6-1. Operating Specifications

Description	210-25	245-25
Drive Speed (slow)	0.2 m/s (0.4mph)	0.2 m/s (0.4mph)
Drive Speed (fast)	1.1 m/s (2.5 mph)	0.86 m/s (1.9 mph)
Lift Speed (platform empty)	95 sec	105 sec
Lowering Speed	70 sec	80 sec
Max Operating Hydraulic Pressure	210 bar (3,046 psi)	
Power Supply	Diesel Engine	
Max. Ground Bearing Pressure: Outriggers Tires	7 kg/cm <sup>2</sup> (100 psi) 5 kg/cm <sup>2</sup> (71 psi)	9 kg/cm <sup>2</sup> (128 psi) 6 kg/cm <sup>2</sup> (85 psi)
Max. Outrigger Pad Load	5915 kg (13,040 lb)	7720 kg (17,020 lb)
Max. Tire Load Rating	5950 kg (13,118 lb)	6620 kg (14,595 lb)
Electrical System Voltage	24V	24V
Gradeability	35%	25%
Ground Clearance	0.27 m (0.9 ft)	0.27 m (0.9 ft)



## Dimensional Data

**Table 6-2. Dimensional Data**

Description	210-25	245-25
Transport Height (rails up)	3.95 m (13 ft)	4.24 m (14 ft)
Platform Height (Stowed)	2.85 m	3.14 m
Platform dimensions (extension retracted)	2.45 x 5.4 m (8 x 18 ft)	2.45 x 5.4 m (8 x 18 ft)
Platform dimensions (extension extended)	2.45 x 7.8 m (8 - 26 ft)	2.45 x 7.8 m (8 - 26 ft)
Transport Dimensions	5.77 x 2.51 x 2.85 m (19 x 8.2 x 9.3 ft)	5.77 x 2.51 x 3.14 m (19 x 8.2 x 10.3 ft)

## Capacities

**Table 6-3. Capacities**

Fuel Tank	90 L (23.8 gal)
Hydraulic Tank	260 L (68.7 gal)
Engine Crankcase with Filter without Filter	10.5 L (11 qt) 10 L (10.6 qt)

## Tires

**Table 6-4. Tire Specifications**

Description	210-25	245-25
Size	315/80R 22.5	

## SECTION 6 - GENERAL SPECIFICATIONS AND OPERATOR MAINTENANCE

### Engine

**Table 6-5. Engine Specifications**

Type	Deutz F4L 2011F; Deutz D2011 L04 i
Displacement	3108 cm <sup>3</sup>
Bore	94 mm
Stroke	112 mm
Fuel Type	Diesel

**Table 6-6. Engine Battery Specifications**

Voltage	12V
Amp Hour	100
Amp	880

### Component Weights

**Table 6-7. Component Weights**

Description	210-25	245-25
Fixed Platform	1,100 kg (2,425 lb)	1,100 kg (2,425 lb)
Chassis with Foam Filled Tires	5,800 kg (12,787 lb)	5,800 kg (12,787 lb)
Arm Assembly	6,400 kg (14,110 lb)	7,100 kg (15,653 lb)

# SECTION 6 - GENERAL SPECIFICATIONS AND OPERATOR MAINTENANCE

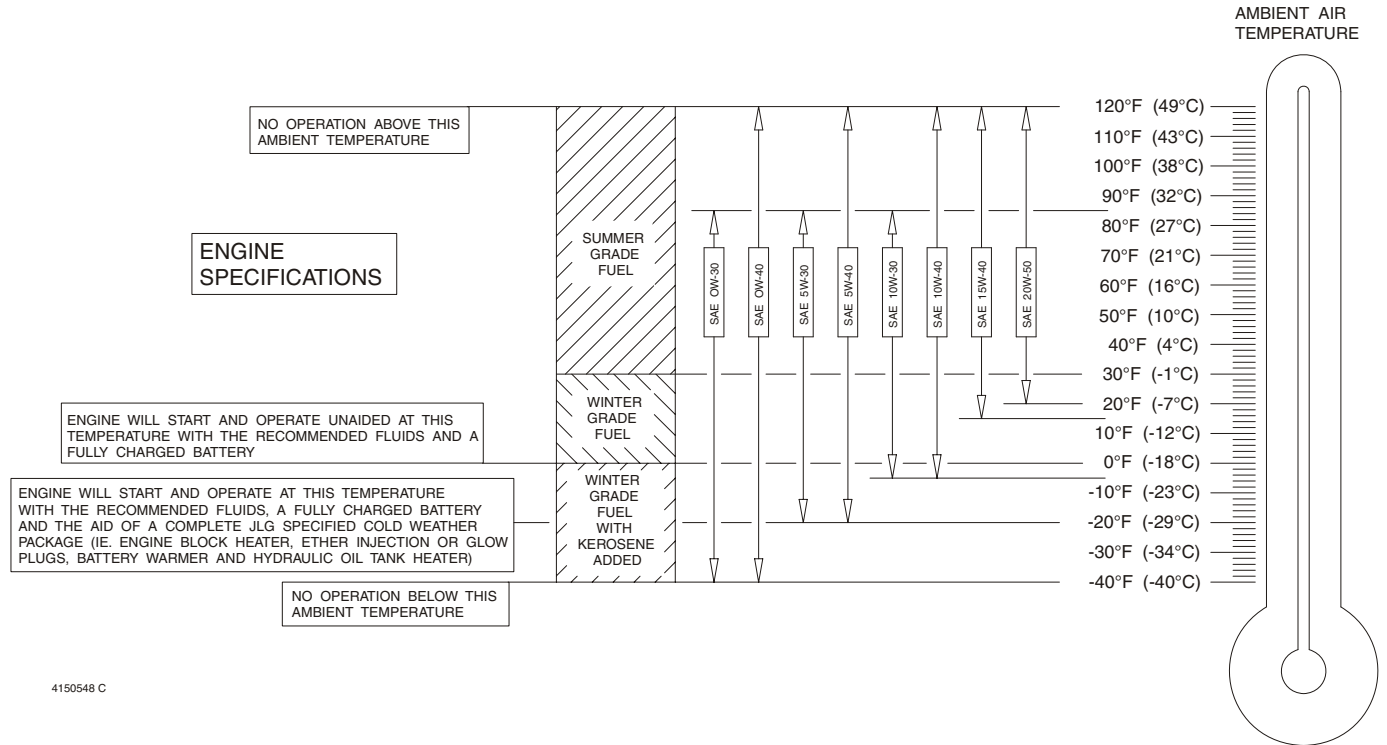

**Figure 6-1. Engine Operating Temperature Specifications (Deutz) - Sheet 1 of 2**

# SECTION 6 - GENERAL SPECIFICATIONS AND OPERATOR MAINTENANCE

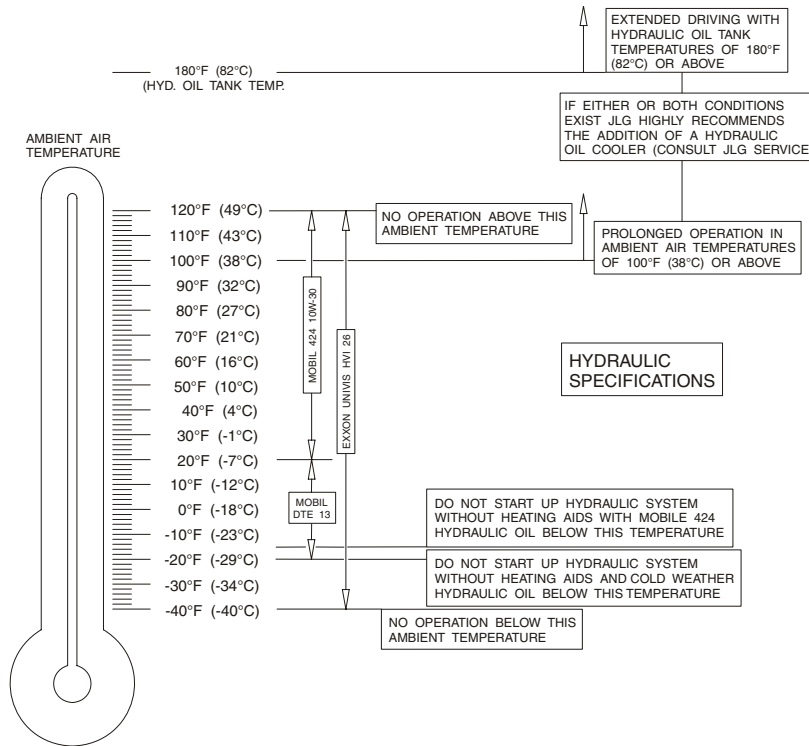

NOTE:

- 1) RECOMMENDATIONS ARE FOR AMBIENT TEMPERATURES CONSISTANTLY WITHIN SHOWN LIMITS
- 2) ALL VALUES ARE ASSUMED TO BE AT SEA LEVEL

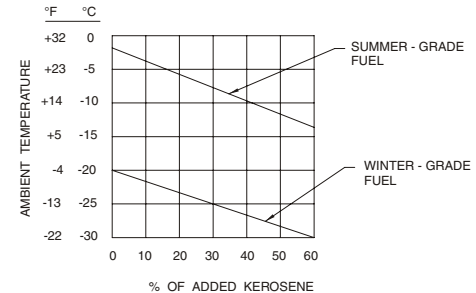

Figure 6-2. Engine Operating Temperature Specifications (Deutz) - Sheet 2 of 2

## SECTION 6 - GENERAL SPECIFICATIONS AND OPERATOR MAINTENANCE

### Lubrication

Hydraulic Oil

**Table 6-8. Hydraulic Oil**

HYDRAULIC SYSTEM OPERATING TEMPERATURE RANGE	SAE VISCOSITY GRADE
-18° to -5° C (0° to +23° F)	10W
-18° to +100° C (0° to +210° F)	10W-20, 10W-30
+10° to +100° C (+50° to +210° F)	20W-20

**NOTE:** Hydraulic oils must have anti-wear qualities at least to API Service Classification GL-3, and sufficient chemical stability for mobile hydraulic system service. JLG Industries recommends Mobilfluid 424 hydraulic oil, which has an SAE viscosity index of 152.

**NOTE:** When temperatures remain below -7° C (20° F), JLG Industries recommends the use of Mobil DTE13.

**NOTE:** Aside from JLG recommendations, it is not advisable to mix oils of different brands or types, as they may not contain the same required additives or be of comparable viscosities. If use of hydraulic oil other than Mobilfluid 424 is desired, contact JLG Industries for proper recommendations.

Lubrication Specifications

**Table 6-9. Lubrication Specifications**

KEY	SPECIFICATIONS
MPG	Multipurpose Grease having a minimum dripping point of 350° F. Excellent water resistance and adhesive qualities, and being of extreme pressure type. (Timken OK 40 pounds minimum.)
EPGL	Extreme Pressure Gear Lube (oil) meeting API service classification GL-5 or MIL-Spec MIL-L-2105.
EO	Engine (crankcase) Oil. Gas - API SF/SG class, MIL-L-2104. Diesel - API CC/CD class, MIL-L-2104B/MIL-L-2104C.
HO	Hydraulic Oil. API service classification GL-3, e.g. Mobil 424.

**6.3 OPERATOR MAINTENANCE**



- 1. Arm Pins
- 2. Outrigger Cylinders
- 3. Engine Compartment
- 4. Tie Rod End
- 5. Spindles
- 6. Oscillating Axle

**Figure 6-3. Operator Maintenance & Lubrication Diagram**

## SECTION 6 - GENERAL SPECIFICATIONS AND OPERATOR MAINTENANCE

**NOTE:** The following numbers correspond with those in Figure 6-3., Operator Maintenance & Lubrication Diagram.

**NOTE:** Be sure to grease all like items on the opposite side of machine.

### 1. Arm Pin



- Lube Points - 36 Grease Fittings
- Capacity - As Required
- Lube - MPG
- Interval - As Required

### 2. Outrigger Cylinders



- Lube Points - 4 Grease Fittings
- Capacity - As Required
- Lube - MPG
- Interval - As Required

## SECTION 6 - GENERAL SPECIFICATIONS AND OPERATOR MAINTENANCE

### 3. Engine Compartment

#### a. Engine Oil Check/Fill



- Lube Points - Fill Cap & Dip Stick
- Capacity - See Engine Manual
- Lube - EO SAE 20W20
- Interval - Every 3 months or 150 hours of operation.

#### b. Air Filter



- Lube Points - Replaceable Element
- Interval - Every 6 months or 300 hours of operation.



## SECTION 6 - GENERAL SPECIFICATIONS AND OPERATOR MAINTENANCE

### c. Hydraulic Oil Check/Fill



- Lube Points - Fill Cap & Site Gage
- Capacity - 260 ltr (68.7 gal)
- Lube - HO
- Interval - Check oil daily, change every 1200 hours of operation.

### 4. Tie RodEnd



- Lube Points - 2 Grease Fittings
- Capacity - As Required
- Lube - MPG
- Interval - As Required

## SECTION 6 - GENERAL SPECIFICATIONS AND OPERATOR MAINTENANCE

### 5. Spindles



- Lube Points - 2 Grease Fittings
- Capacity - As Required
- Lube - MPG
- Interval - As required

### 6. Oscillating Axle



- Lube Points - 3 Grease Fittings
- Capacity - As Required
- Lube - MPG
- Interval - As Required

### 7. Fuel Tank (Opposite Engine Compartment)



- Capacity - 90 ltr (23.8 gal)
- Lube - Diesel Fuel
- Interval - Check fuel periodically during each shift.

## 6.4 TIRES AND WHEELS

### Tire Damage

For pneumatic tires, JLG Industries, Inc. recommends that when any cut, rip, or tear is discovered that exposes sidewall or tread area cords in the tire, measures must be taken to remove the JLG product from service immediately. Arrangements must be made for replacement of the tire or tire assembly.

For polyurethane foam filled tires, JLG Industries, Inc. recommends that when any of the following are discovered, measures must be taken to remove the JLG product from service immediately and arrangements must be made for replacement of the tire or tire assembly.

- a smooth, even cut through the cord plies which exceeds 7.5 cm (3 inches) in total length
- any tears or rips (ragged edges) in the cord plies which exceeds 2.5 cm (1 inch) in any direction
- any punctures which exceed 2.5cm in diameter
- any damage to the bead area cords of the tire

If a tire is damaged but is within the above noted criteria, the tire must be inspected on a daily basis to insure the damage has not propagated beyond the allowable criteria.

### **Tire Replacement**

JLG recommends a replacement tire be the same size, ply and brand as originally installed on the machine. Please refer to the JLG Parts Manual for the part number of the approved tires for a particular machine and model. If not using a JLG approved replacement tire, we recommend that replacement tires have the following characteristics:

- Equal or greater ply/load rating and size of original
- Tire tread contact width equal or greater than original
- Wheel diameter, width, and offset dimensions equal to the original.

Unless specifically approved by JLG Industries Inc. do not replace a foam filled tire assembly with a pneumatic tire. When selecting and installing a replacement tire, ensure that all tires are inflated to the pressure recommended by JLG. Due to size variations between tire brands, both tires on the same axle should be the same.

### **Wheel Replacement**

The rims installed on each product model have been designed for stability requirements which consist of track width, tire pressure, and load capacity. Size changes such as rim width, center piece location, larger or smaller diameter, etc., without written factory recommendations, may result in an unsafe condition regarding stability.

## Wheel Installation

It is extremely important to apply and maintain proper wheel mounting torque.

### **⚠ WARNING**

**WHEEL NUTS MUST BE INSTALLED AND MAINTAINED AT THE PROPER TORQUE TO PREVENT LOOSE WHEELS, BROKEN STUDS, AND POSSIBLE DANGEROUS SEPARATION OF WHEEL FROM THE AXLE. BE SURE TO USE ONLY THE NUTS MATCHED TO THE CONE ANGLE OF THE WHEEL.**

Tighten the lug nuts to the proper torque to prevent wheels from coming loose. Use a torque wrench to tighten the fasteners. If you do not have a torque wrench, tighten the fasteners with a lug wrench, then immediately have a service garage or dealer tighten the lug nuts to the proper torque. Over-tightening will result in breaking the studs or permanently deforming the mounting stud holes in the wheels. The proper procedure for attaching wheels is as follows:

1. Start all nuts by hand to prevent cross threading. DO NOT use a lubricant on threads or nuts.
2. Tighten nuts in the following sequence:

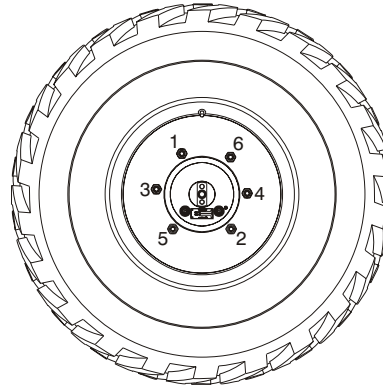

6 LUG PATTERN

3. The tightening of the nuts should be done in stages. Following the recommended sequence, tighten the nuts per wheel torque chart.

TORQUE SEQUENCE		
1st Stage	2nd Stage	3rd Stage
150-190 ft lbs (210 - 270 Nm)	230 - 270 ft lbs (320-380 Nm)	305 - 343 ft lbs (440 - 480 Nm)

4. Wheel nuts should be torqued after the first 50 hours of operation and after each wheel removal. Check torque every 3 months or 150 hours of operation.

### **6.5 LSS TESTING AND EVALUATION**

Confirm Load Sensing System Performance with Calibrated Weights:

1. Operate the vehicle from Ground Control and place the platform in the fully stowed position for safety. Place 120% of the machines rated load in the center of the platform and ensure that the overload visual and audible warnings are active. Reduce the platform load to 100% rated load and ensure that the warnings are not active. For vehicles with multiple capacities, evaluate each operating mode with the proper rated load.









An Oshkosh Corporation Company

# TRANSFER OF OWNERSHIP

## To Product Owner:

If you now own but **ARE NOT** the original purchaser of the product covered by this manual, we would like to know who you are. For the purpose of receiving safety-related bulletins, it is very important to keep JLG Industries, Inc. updated with the current ownership of all JLG products. JLG maintains owner information for each JLG product and uses this information in cases where owner notification is necessary.

Please use this form to provide JLG with updated information with regard to the current ownership of JLG products. Please return completed form to the JLG Product Safety & Reliability Department via facsimile or mail to address as specified below.

Thank You,  
Product Safety & Reliability Department  
*JLG Industries, Inc.*  
13224 Fountainhead Plaza  
Hagerstown, MD 21742  
USA  
Telephone: +1-717-485-6591  
Fax: +1-301-745-3713

**NOTE:** Leased or rented units should not be included on this form.

Mfg. Model: \_\_\_\_\_

Serial Number: \_\_\_\_\_

Previous Owner: \_\_\_\_\_

Address: \_\_\_\_\_

Country: \_\_\_\_\_ Telephone: (\_\_\_\_) \_\_\_\_\_

Date of Transfer: \_\_\_\_\_

Current Owner: \_\_\_\_\_

Address: \_\_\_\_\_

Country: \_\_\_\_\_ Telephone: (\_\_\_\_) \_\_\_\_\_

**Who in your organization should we notify?**

Name: \_\_\_\_\_

Title: \_\_\_\_\_







An Oshkosh Corporation Company

Corporate Office  
JLG Industries, Inc.  
1 JLG Drive  
McConnellsburg PA. 17233-9533  
USA

(717) 485-5161

(717) 485-6417

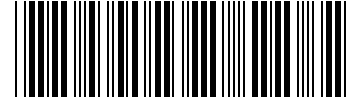

3121303

## JLG Worldwide Locations

JLG Industries (Australia)  
P.O. Box 5119  
11 Bolwarra Road  
Port Macquarie  
N.S.W. 2444  
Australia

+61 2 65 811111

+61 2 65 810122

JLG Latino Americana Ltda.  
Rua Eng. Carlos Stevenson,  
80-Suite 71  
13092-310 Campinas-SP  
Brazil

+55 19 3295 0407

+55 19 3295 1025

JLG Industries (UK) Ltd  
Bentley House  
Bentley Avenue  
Middleton  
Greater Manchester  
M24 2GP - England

+44 (0)161 654 1000

+44 (0)161 654 1001

JLG France SAS  
Z.I. de Baulieu  
47400 Failliet  
France

+33 (0)5 53 88 31 70

+33 (0)5 53 88 31 79

JLG Deutschland GmbH  
Max-Planck-Str. 21  
D - 27721 Ritterhude - Ihlpohl  
Germany

+49 (0)421 69 350 20

+49 (0)421 69 350 45

JLG Equipment Services Ltd.  
Rm 1107 Landmark North  
39 Lung Sum Avenue  
Sheung Shui N. T.  
Hong Kong

(852) 2639 5783

(852) 2639 5797

JLG Industries (Italia) s.r.l.  
Via Po. 22  
20010 Pregnana Milanese - MI  
Italy

+39 029 359 5210

+39 029 359 5845

JLG Europe B.V.  
Polaris Avenue 63  
2132 JH Hoofddorp  
The Netherlands

+31 (0)23 565 5665

+31 (0)23 557 2493

JLG Polska  
Ul. Krolewska  
00-060 Warszawa  
Poland

+48 (0)914 320 245

+48 (0)914 358 200

JLG Industries (Scotland)  
Wright Business Centre  
1 Lonmay Road  
Queenslie, Glasgow G33 4EL  
Scotland

+44 (0)141 781 6700

+44 (0)141 773 1907

Plataformas Elevadoras  
JLG Iberica, S.L.  
Trapadella, 2  
P.I. Castellbisbal Sur  
08755 Castellbisbal, Barcelona  
Spain

+34 93 772 4700

+34 93 771 1762

JLG Sverige AB  
Enkopingsvagen 150  
Box 704  
SE - 176 27 Jarfalla  
Sweden

+46 (0)850 659 500

+46 (0)850 659 534